

# 1260 VXI SWITCHING CARD

## 1260-14C OPEN COLLECTOR DIGITAL I/O MODULE

PUBLICATION NO. 980673-012

### RACAL INSTRUMENTS

**Racal Instruments, Inc.**

4 Goodyear St., Irvine, CA 92618-2002  
Tel: (800) 722-3262, FAX: (949) 859-7309

**Racal Instruments, Ltd.**

480 Bath Road, Slough, Berkshire, SL1 6BE, United Kingdom  
Tel: +44 (0) 8706 080134; FAX: +44 (0) 1753 791290

**Racal Systems Electronique S.A.**

18 Avenue Dutartre, 78150 LeChesnay, France  
Tel: +33 (1) 3923 2222; FAX: +33 (1) 3923 2225

**Racal Systems Elettronica s.r.l.**

Strada 2-Palazzo C4, 20090 Milanofiori Assago, Milan, Italy  
Tel: +39 (02) 5750 1796; FAX +39 (02) 5750 1828

**Racal Elektronik System GmbH.**

Frankenforster Strasse 21, 51427 Bergisch Gladbach, Germany  
Tel: +49 2204 92220; FAX: +49 2204 21491

**Racal Australia Pty. Ltd.**

3 Powells Road, Brookvale, NSW 2100, Australia  
Tel: +61 (2) 9936 7000, FAX: +61 (2) 9936 7036

**Racal Electronics Pte. Ltd.**

26 Ayer Rajah Crescent, 04-06/07 Ayer Rajah Industrial Estate, Singapore 0513.  
Tel: +65 7792200, FAX: +65 7785400

**Racal Instruments, Ltd.**

Unit 5, 25F., Mega Trade Center, No 1, Mei Wan Road, Tsuen Wan, Hong Kong, PRC  
Tel: +852 2405 5500, FAX: +852 2416 4335

<http://www.racalinst.com>

The RACAL logo consists of the word "RACAL" in a bold, sans-serif font. Each letter is contained within a rectangular box, and the boxes are arranged in a slightly staggered, overlapping manner.

---

**PUBLICATION DATE: June 29, 1998**

Copyright 1997 by Racal Instruments, Inc. Printed in the United States of America. All rights reserved.  
This book or parts thereof may not be reproduced in any form without written permission of the publisher.

---

---

## WARRANTY STATEMENT

---

---

All Racal Instruments, Inc. products are designed and manufactured to exacting standards and in full conformance to Racal's ISO 9001 procedures.

For the specific terms of your standard warranty, or optional extended warranty or service agreement, contact your Racal customer service advisor. Please have the following information available to facilitate service.

1. Product serial number
2. Product model number
3. Your company and contact information

You may contact your customer service advisor by:

E-Mail:	<a href="mailto:Helpdesk@racalstruments.com">Helpdesk@racalstruments.com</a>	
Telephone:	+1 800 722 3262	(USA)
	+44(0) 8706 080134	(UK)
	+852 2405 5500	(Hong Kong)
Fax:	+1 949 859 7309	(USA)
	+44(0) 1628 662017	(UK)
	+852 2416 4335	(Hong Kong)

---

---

## RETURN of PRODUCT

---

---

Authorization is required from Racal Instruments before you send us your product for service or calibration. Call your nearest Racal Instruments support facility. A list is located on the last page of this manual. If you are unsure where to call, contact Racal Instruments, Inc. Customer Support Department in Irvine, California, USA at 1-800-722-3262 or 1-949-859-8999 or via fax at 1-949-859-7139. We can be reached at: [helpdesk@racalstruments.com](mailto:helpdesk@racalstruments.com).

---

---

## PROPRIETARY NOTICE

---

---

This document and the technical data herein disclosed, are proprietary to Racal Instruments, and shall not, without express written permission of Racal Instruments, be used, in whole or in part to solicit quotations from a competitive source or used for manufacture by anyone other than Racal Instruments. The information herein has been developed at private expense, and may only be used for operation and maintenance reference purposes or for purposes of engineering evaluation and incorporation into technical specifications and other documents which specify procurement of products from Racal Instruments.

---

# FOR YOUR SAFETY

---

Before undertaking any troubleshooting, maintenance or exploratory procedure, read carefully the **WARNINGS** and **CAUTION** notices.

This equipment contains voltage hazardous to human life and safety, and is capable of inflicting personal injury.

If this instrument is to be powered from the AC line (mains) through an autotransformer, ensure the common connector is connected to the neutral (earth pole) of the power supply.

Before operating the unit, ensure the conductor (green wire) is connected to the ground (earth) conductor of the power outlet. Do not use a two-conductor extension cord or a three-prong/two-prong adapter. This will defeat the protective feature of the third conductor in the power cord.

Maintenance and calibration procedures sometimes call for operation of the unit with power applied and protective covers removed. Read the procedures and heed warnings to avoid "live" circuit points.

Before operating this instrument:

1. Ensure the instrument is configured to operate on the voltage at the power source. See Installation Section.
2. Ensure the proper fuse is in place for the power source to operate.
3. Ensure all other devices connected to or in proximity to this instrument are properly grounded or connected to the protective third-wire earth ground.

If the instrument:

- fails to operate satisfactorily
- shows visible damage
- has been stored under unfavorable conditions
- has sustained stress

Do not operate until performance is checked by qualified personnel.

This page was left intentionally blank.

## Table Of Contents

### Chapter 1

MODULE SPECIFICATION .....	1-1
Module Specification .....	1-1
Specifications .....	1-3
Pin Configuration .....	1-4

### Chapter 2

INSTALLATION INSTRUCTIONS .....	2-1
Unpacking and Inspection .....	2-1
Reshipment Instructions.....	2-2
Option 01 Installation .....	2-2
Module Installation .....	2-2

### Chapter 3

MODULE SPECIFIC SYNTAX.....	3-1
Asynchronous and Synchronous Modes of Operation.....	3-1
Asynchronous Mode .....	3-1
Synchronous Mode.....	3-2
Synchronous Mode Handshaking.....	3-3
Module Specific Syntax .....	3-4
Syntax Notations and Conventions .....	3-5
Definition of Commands .....	3-6
PDATAOUT command.....	3-6
PSETUP command.....	3-8
READ command .....	3-9
RESET command .....	3-12
SETUP ARM command.....	3-12
SETUP BUSY command.....	3-13
SETUP CLKIN command.....	3-13
SETUP RD command .....	3-14

SETUP SYNC command .....3-16  
SETUP WR command .....3-17  
WRITE command .....3-20  
Synchronous Mode Example .....3-24

Chapter 4

DRAWINGS .....4-1

Chapter 5

PARTS LIST .....5-1

Chapter 6

OPTIONAL HARNESS ASSEMBLIES .....6-1

Chapter 7

Product Support .....7-1  
Reshipment Instructions .....7-1

## List Of Figures

Figure 1-1, 1260-14C Block Diagram.....	1-2
Figure 1-2, Model 1260-14C Front Panel and Pin Configuration.....	1-6
Figure 1-3 Allowable Package Power Dissipation of Output Stage .....	1-11
Figure 1-4, $V_{ce}$ (sat) as a Function of Collector Current .....	1-11
Figure 2-1, 1260-14C.....	2-1
Figure 3-1, Model 1260-14C Input and Output Handshake Modes .....	3-4

## List Of Tables

Table 1-1, Model 1260-14C Channels and Ports .....	1-5
Table 1-2, Model 1260-14C Pins, Signals and Descriptions .....	1-7
Table 1-2, Model 1260-14C Pins, Signals and Descriptions (continued).....	1-8
Table 1-2, Model 1260-14C Pins, Signals and Descriptions (continued).....	1-9
Table 1-2, Model 1260-14C Pins, Signals and Descriptions (continued).....	1-10

This page was left intentionally blank.



## Chapter 1

# MODULE SPECIFICATION

---

### Module Specification

The 1260-14C provides 96 Open Collector (OC) I/O lines in twelve groups of 8 bits each. Each group of 8 bits (hereafter referred to as a port) can be read from or written to asynchronously using the commands READ and WRITE. Additionally, up to 12 ports may be grouped together and synchronously operated using an external clock for as many as 256 consecutive operations by using the appropriate SETUP commands. The last data previously written to or read from a port is retrieved by using the PDATAOUT command. The current state of the 1260-14C is determined by using the PSETUP command. Refer to the individual syntax descriptions for each command and the examples given later for the specifics regarding these operations.

The outputs of the 1260-14C are connected to an external voltage that provides inductive fly-back protection. If inductive loads are to be driven, the external voltage must be supplied to the module. Failure to do so may cause damage to the module's output stage. If protection for inductive voltage fly-back is unnecessary,  $V_{ext}$  does not need to be supplied to the module.

The 1260-14C allows twelve separate external voltages to be supplied to the module's front panel. These external voltages are supplied to the output stages on a byte-by-byte basis. This allows some flexibility as to the OC output voltages that are supported simultaneously by the module (see the 1260-14C Block Diagram). Also, the VXIbus supplied voltages (+5V, +12V, and +24V) are used to pull up the output stage if the module is fitted with internal resistive pull-ups.

The 1260-14C includes provisions for the installation of internal pull-up resistors. This includes twelve 16-pin DIP sockets designed to accommodate standard 16-pin, eight resistor-isolated style DIP packages, such as CTS P/N 761-3-R10k or Bourns P/N 4116R-001-103. The 1260-14C contains no internal pull-up resistors at time of shipment.

It is recommended that outputs be pulled-up with 10k $\Omega$  resistors if driving standard logic gates. Internal pull-ups are limited to a minimum value of 10k $\Omega$  due to the amount of current available

from the VXIbus supplies.

The output stage of the 1260-14C may sink up to 200mA. The limitation to this is the power dissipation in the output stages of the IC. (See Figure 1-3 for the maximum allowable package power dissipation.) If many 200mA loads are to be driven, they should be distributed across the module's outputs for improved thermal management.

It should be noted that there is no tri-state capability on the 1260-14C. Since the outputs are open collector, they are placed in a pseudo tri-state by "driving" a 1 on the relevant channel. In this way, the channels are controlled on a bit-by-bit basis rather than a byte-by-byte basis as on the standard 1260-14.

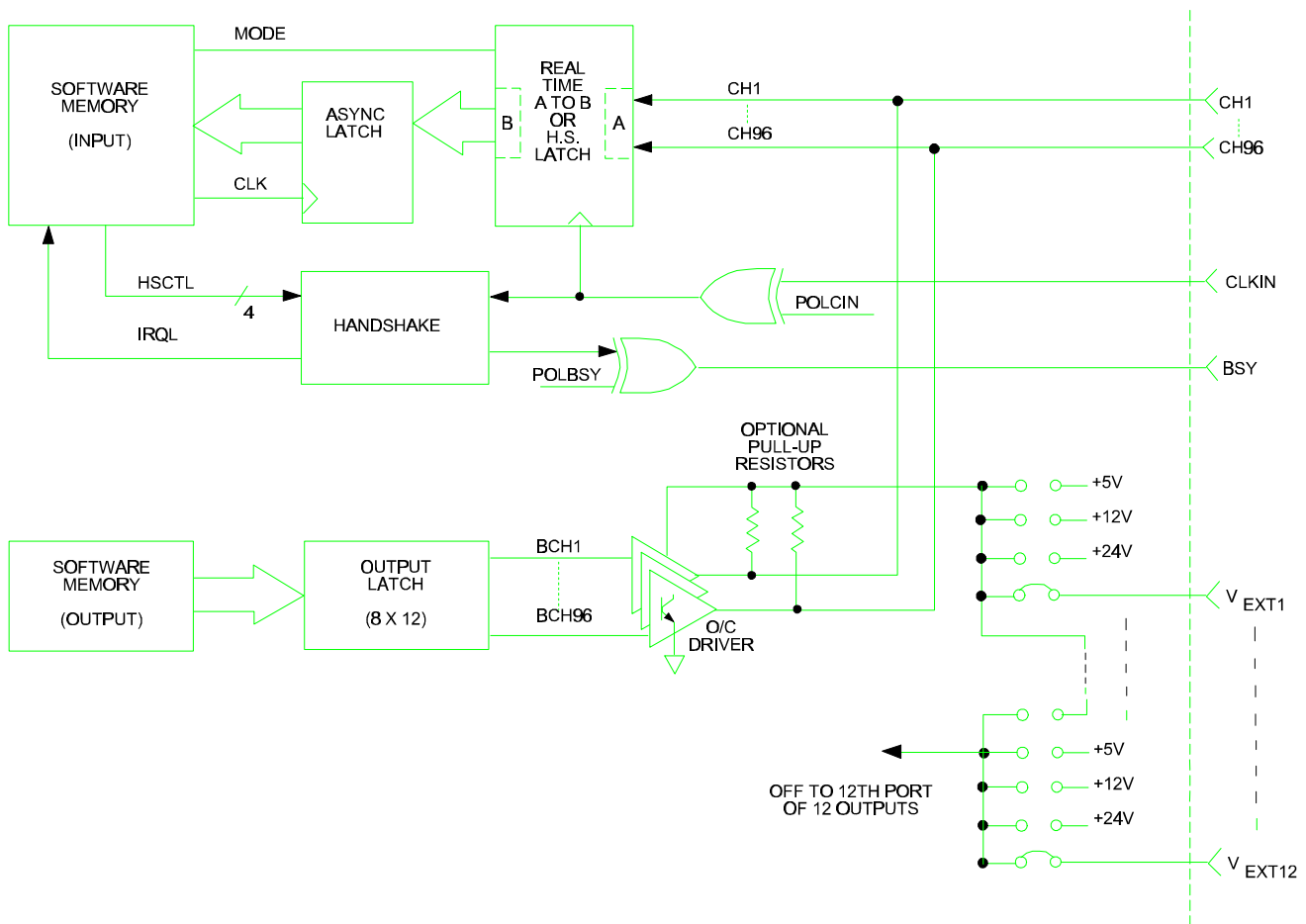

Figure 1-1, 1260-14C Block Diagram

## Specifications

User Connector	Two 50-pin IDC and two 60-pin IDC
Number of I/O Channels	96 Channels
Configuration	I/O lines selected as either input or output on a pin-per-pin basis
Data Rate	Static to approximately 1 kHz
Operating Modes	Asynchronous Synchronous
Input/Output	Open Collector*

All outputs have inductive-load transient suppression diodes built in, and must be supplied with an external voltage source ( $V_{ext}$ ) for this protection to be active.

---

### CAUTION

**Damage to the driver's output may occur if a highly inductive load (i.e., relay coil drive) is driven without an external voltage ( $V_{ext}$ ) being applied to the module's drive cells.**

---

$V_{ext}$  may differ on a port-by-port basis, or can be jumpered across all the drivers. The factory setting is to connect each port with its corresponding  $V_{ext}$  pin where  $V_{ext}$  (1-12) are the user's input pins to the drivers. The outputs may also be internally pulled up if fitted with DIP resistor packs (this selection is also port- wide).

---

### NOTE

**$V_{ext}$  is limited to 1A per  $V_{ext}$  pin used. For example, the maximum current-carrying capability of a single  $V_{ext}$  pin is 1A.**

---

\* A CMOS-compatible and LS TTL versions of the 1260-14C are also available.

#### Output Voltage

$V_{out}$ (High)	$5.0\text{ V} \leq V_{oh} \leq 32\text{ V (max)}$
$V_{out}$ (Low)	$\leq 1.5\text{ V at } I_{in\ lo} = 200\text{ mA}$

#### Input Voltage

$V_{in}$ (High)	$\geq 2\text{ V}$
$V_{in}$ (Low)	$\leq 1.5\text{ V}$

$V_{ih}$ (Max)	32 VDC
Input Resistance	>500k $\Omega$
Cooling Requirement	
Airflow	1.2 liters/sec
Backpressure	0.6mm H <sub>2</sub> O
Power Requirement ( $I_{pm}$ )	
5V	2.38A (4.78A with Option 01)
Weight	2.69 lbs (1.21 Kg) 2.97 lbs (1.34 Kg with Option 01)
Minimum Option 01 Firmware	
Revision	17.1

---

**CAUTION**

**Damage to user's equipment or to the Digital I/O card could occur if the user enables an output driver (driver outputting a low) for a channel connected to a device that is attempting to drive the data line high.**

---



---

## Pin Configuration

The 1260-14C Digital I/O module has 96 channels, grouped as twelve 8-bit ports available at front panel connectors J1 through J4. Each port may be configured as an input or an output.

Refer to Figure 1-2 for the pin configurations of the 50 and 60 pin connectors on the front panel, and to Table 1-1 for correspondence between the physical channel assignments and the port numbers used in the command codes.

Refer to Table 1-2 for correspondence between the front panel pins and the signal names and descriptions.

**Table 1-1, Model 1260-14C Channels and Ports**

Channel No.	Port No.	External Pull-Up Voltage
1 - 8	0	$V_{\text{ext 1}}$
9 - 16	1	$V_{\text{ext 2}}$
17 - 24	2	$V_{\text{ext 3}}$
25 - 32	3	$V_{\text{ext 4}}$
33 - 40	4	$V_{\text{ext 5}}$
41 - 48	5	$V_{\text{ext 6}}$
49 - 56	6	$V_{\text{ext 7}}$
57 - 64	7	$V_{\text{ext 8}}$
65 - 72	8	$V_{\text{ext 9}}$
73 - 80	9	$V_{\text{ext 10}}$
81 - 88	10	$V_{\text{ext 11}}$
89 - 96	11	$V_{\text{ext 12}}$

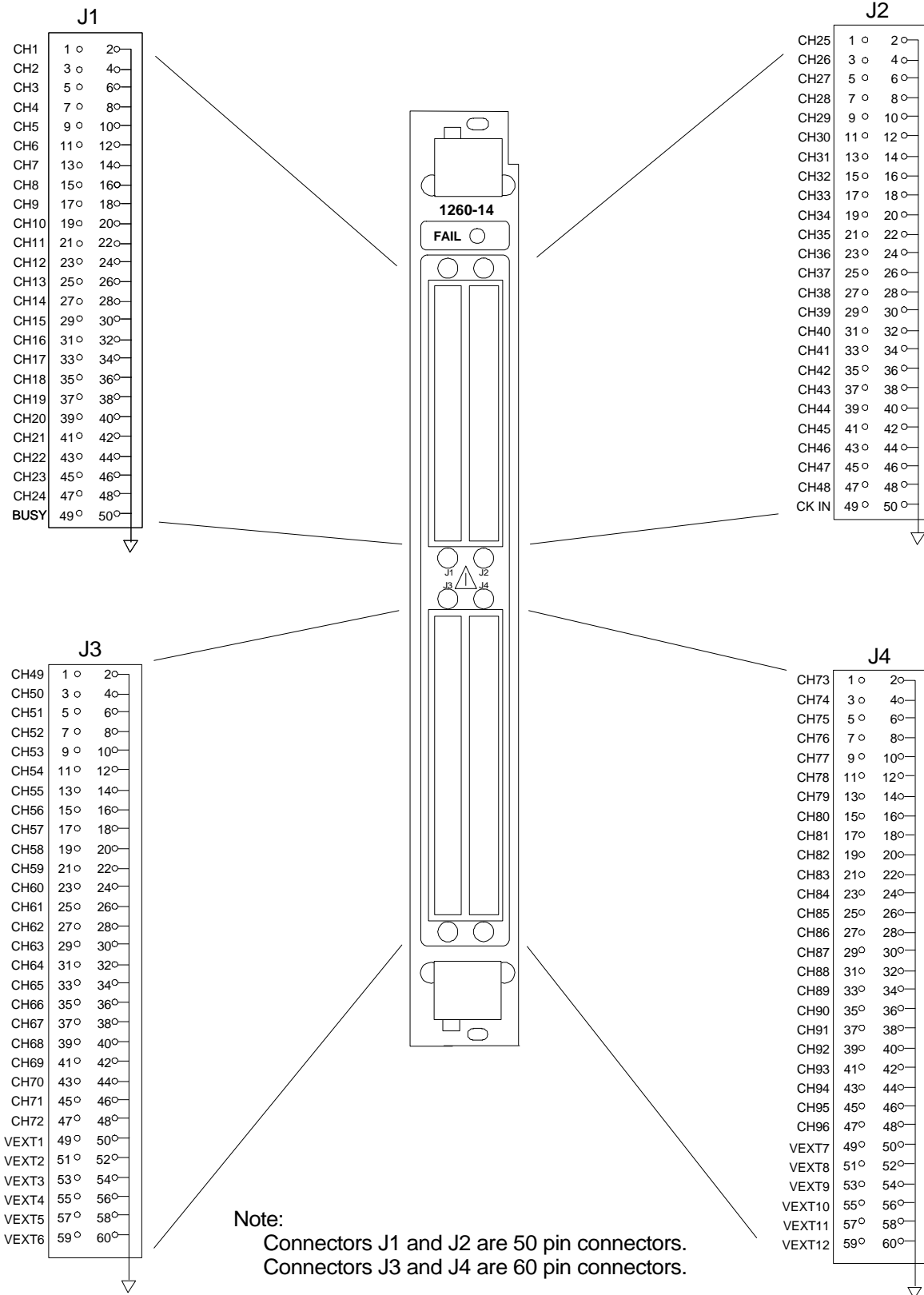

Figure 1-2, Model 1260-14C Front Panel and Pin Configuration

**Table 1-2, Model 1260-14C Pins, Signals and Descriptions**

J1 Pin	Row A Signal	Description
1	CH1	Channel 1 I/O
3	CH2	Channel 2 I/O
5	CH3	Channel 3 I/O
7	CH4	Channel 4 I/O
.	.	.
.	.	.
.	.	.
45	CH23	Channel 23 I/O
47	CH24	Channel 24 I/O
49	BSY	BUSY Handshake output

J1 Pin	Row B Signal	Description
2	GND	Channel 1 RTN
4	GND	Channel 2 RTN
6	GND	Channel 3 RTN
8	GND	Channel 4 RTN
.	.	.
.	.	.
.	.	.
44	GND	Channel 22 RTN
46	GND	Channel 23 RTN
48	GND	Channel 24 RTN
50	GND	BUSY Signal return

**Table 1-2, Model 1260-14C Pins, Signals and Descriptions (continued)**

J2 Pin	Row A Signal	Description
1	CH25	Channel 25 I/O
3	CH26	Channel 26 I/O
5	CH27	Channel 27 I/O
7	CH28	Channel 28 I/O
.	.	.
.	.	.
.	.	.
45	CH47	Channel 47 I/O
47	CH48	Channel 48 I/O
49	CLKIN	CLKIN Handshake input

J2 Pin	Row B Signal	Description
2	GND	Channel 25 RTN
4	GND	Channel 26 RTN
6	GND	Channel 27 RTN
8	GND	Channel 28 RTN
.	.	.
.	.	.
.	.	.
44	GND	Channel 46 RTN
46	GND	Channel 47 RTN
48	GND	Channel 48 RTN
50	GND	CLKIN Signal return



**Table 1-2, Model 1260-14C Pins, Signals and Descriptions (continued)**

J3 Pin	Row A Signal	Description
1	CH49	Channel 49 I/O
3	CH50	Channel 50 I/O
5	CH51	Channel 51 I/O
7	CH52	Channel 52 I/O
.	.	.
.	.	.
.	.	.
45	CH71	Channel 71 I/O
47	CH72	Channel 72 I/O
49	V <sub>ext</sub> 1	External Voltage 1
51	V <sub>ext</sub> 2	External Voltage 2
53	V <sub>ext</sub> 3	External Voltage 3
55	V <sub>ext</sub> 4	External Voltage 4
57	V <sub>ext</sub> 5	External Voltage 5
59	V <sub>ext</sub> 6	External Voltage 6

J3 Pin	Row B Signal	Description
2	GND	Channel 49 RTN
4	GND	Channel 50 RTN
6	GND	Channel 51 RTN
8	GND	Channel 52 RTN
.	.	.
.	.	.
.	.	.
44	GND	Channel 70 RTN
46	GND	Channel 71 RTN
48	GND	Channel 72 RTN
50	GND	V <sub>ext</sub> 1 RTN
52	GND	V <sub>ext</sub> 2 RTN
54	GND	V <sub>ext</sub> 3 RTN
56	GND	V <sub>ext</sub> 4 RTN
58	GND	V <sub>ext</sub> 5 RTN
60	GND	V <sub>ext</sub> 6 RTN

Table 1-2, Model 1260-14C Pins, Signals and Descriptions (continued)

J4 Pin	Row A Signal	Description
1	CH73	Channel 73 I/O
3	CH74	Channel 74 I/O
5	CH75	Channel 75 I/O
7	CH76	Channel 76 I/O
.	.	.
.	.	.
.	.	.
45	CH95	Channel 95 I/O
47	CH96	Channel 96 I/O
49	V <sub>ext</sub> 7	External Voltage 7
51	V <sub>ext</sub> 8	External Voltage 8
53	V <sub>ext</sub> 9	External Voltage 9
55	V <sub>ext</sub> 10	External Voltage 10
57	V <sub>ext</sub> 11	External Voltage 11
59	V <sub>ext</sub> 12	External Voltage 12

J4 Pin	Row B Signal	Description
2	GND	Channel 73 RTN
4	GND	Channel 74 RTN
6	GND	Channel 75 RTN
8	GND	Channel 76 RTN
.	.	.
.	.	.
.	.	.
44	GND	Channel 94 RTN
46	GND	Channel 95 RTN
48	GND	Channel 96 RTN
50	GND	V <sub>ext</sub> 7 RTN
52	GND	V <sub>ext</sub> 8 RTN
54	GND	V <sub>ext</sub> 9 RTN
56	GND	V <sub>ext</sub> 10 RTN
58	GND	V <sub>ext</sub> 11 RTN
60	GND	V <sub>ext</sub> 12 RTN

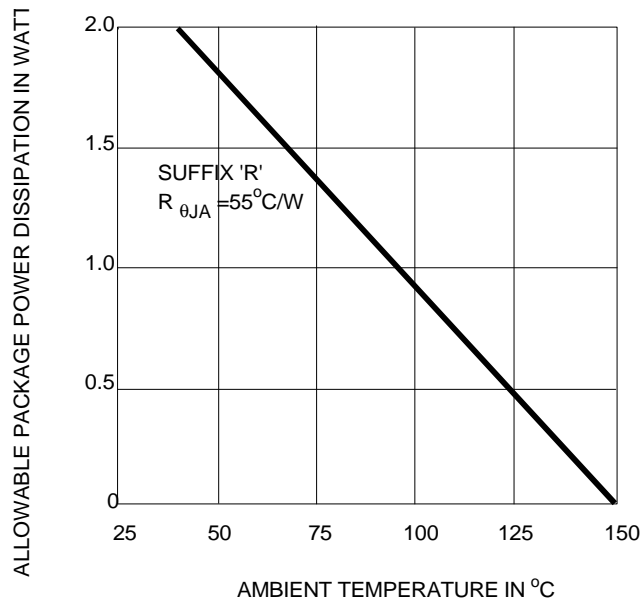

Figure 1-3 Allowable Package Power Dissipation of Output Stage

COLLECTOR CURRENT  
 AS A FUNCTION OF SATURATION VOLTAGE

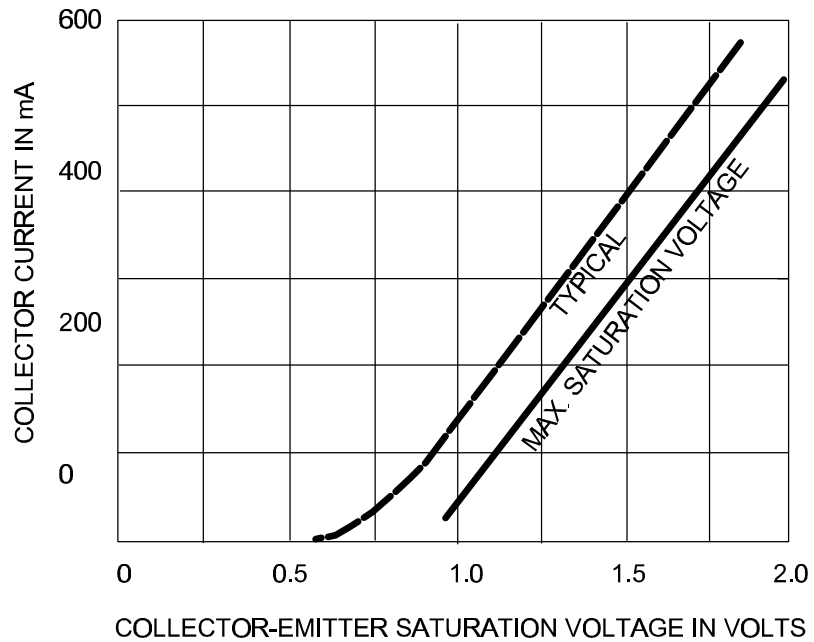

Figure 1-4,  $V_{ce}(\text{sat})$  as a Function of Collector Current

This page was intentionally left blank

## INSTALLATION INSTRUCTIONS

---

### Unpacking and Inspection

1. Before unpacking the 1260-14C, check the exterior of the shipping carton for any signs of damage. All irregularities should be noted on the shipping bill.
2. Remove the module from its carton, preserving the factory packaging as much as possible.
3. Inspect the module for any defect or damage. Immediately notify the carrier if any damage is apparent.
4. Have a qualified person check the instrument for safety before use.

---

#### **CAUTION**

**Proper ESD handling procedures must always be used when packing, unpacking or installing any 1260 Series cards. Failure to do so may cause damage to the unit.**

---

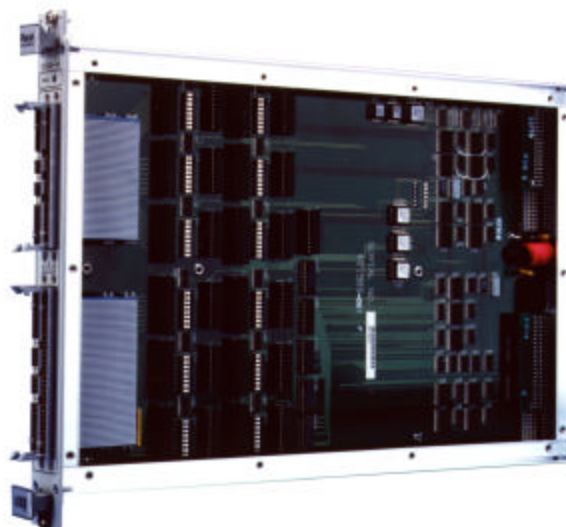

Figure 2-1, 1260-14C

## **Reshipment Instructions**

1. Use the original packaging when returning the 1260-14C module to Racal Instruments for calibration or servicing. The original shipping carton and the module's foam will provide the necessary support for safe reshipment.
2. If the original packaging is unavailable, wrap the module in plastic sheeting and use plastic spray foam to surround and protect the module.
3. Reship in either the original or a new shipping carton.

## **Option 01 Installation**

Installation of the Option 01 into the 1260-14C is described in the Installation section of the 1260 Series VXI Switching Cards Manual (RII P/N 980673-999).

## **Module Installation**

Installation of the 1260-14C Digital I/O Module into a VXIbus mainframe, including the setting of DIP switches, is described in the Installation section of the 1260 Series VXI Switching Cards Manual (RII P/N 980673-999). The ID byte DIP switches, SW1-5 and SW1-6, should be set to OFF.

## MODULE SPECIFIC SYNTAX

---

### Asynchronous and Synchronous Modes of Operation

Each port on the 1260-14C can operate in either an asynchronous or a synchronous mode. The number of synchronous mode ports is modified by using the SETUP SYNC command. The default after power-up or reset is for all ports to be in the asynchronous mode. The current operating mode of the ports is determined at any time with the PSETUP command. See the syntax description of the PSETUP and SETUP SYNC commands for details and examples.

---

### Asynchronous Mode

The asynchronous mode allows data to be read from or written to a port in response to a READ or WRITE command. The following restrictions apply to all asynchronous operations:

Those ports defined as asynchronous cannot participate in synchronous operations.

Asynchronous commands are not allowed on any port while synchronous operations are armed and waiting for clocks.

Asynchronous WRITE commands are valid on synchronous ports to allow the synchronous port to be preset to a starting value. Asynchronous READ commands are not allowed on synchronous ports.

## Synchronous Mode

The synchronous mode of operation allows data to be read from or written to a port in response to a clock edge. Typically, this is done by:

1. Defining the test parameters and data via the various SETUP commands.
2. Arming the test via the SETUP <address>.ARM ON command.
3. Applying a series of TTL clock inputs to the CLKIN line until the last operation on all ports has been completed, causing the test to automatically disarm. It is also possible to manually disarm the test before it has completed all of the test vectors. This is done via the SETUP <address>.ARM OFF command.
4. Reading back the results using the PDATAOUT command.

The following restrictions apply to all synchronous operations:

Synchronous ports are always grouped together and are always the lowest numbered ports; i.e., the first synchronous port is always port 0; the second is always port 1, etc.

All ports not specified as synchronous are asynchronous by default.

A port may read or write during synchronous operations, but not both.

Once a synchronous test is set up, it must be armed before the unit enables the handshake lines.

Synchronous operations cannot be set up once the 1260-14C is armed.

There is a maximum of 256 synchronous operations (referred to as vectors) per port.

All synchronous ports are clocked simultaneously; i.e., if five synchronous ports are defined, the first active edge of the clock causes the appropriate action to occur on all five ports.

Synchronous ports support the asynchronous WRITE command, but not the asynchronous READ command.



## **Synchronous Mode Handshaking**

The module has a two-line handshake available for use in the synchronous mode. The first is the BUSY line, which is set by the 1260-14C when it is busy processing, and the second is the CLKIN line which the user toggles to clock the next synchronous operation. The user specifies the polarity of the BUSY line and the active edge of the CLKIN line by using the appropriate SETUP command. (Refer to Figure 3-1 for timing diagrams of the input and output handshaking modes available.) Both the BUSY and CLKIN lines are valid only when a synchronous operation is defined and armed.

---

### ***NOTE***

**Both the BUSY and the CLKIN lines are valid only when synchronous operations are defined and armed. Changes on the CLKIN line are ignored by the 1260-14C when the card is not armed. Spurious outputs on the BUSY line should also be ignored unless the unit is armed.**

---

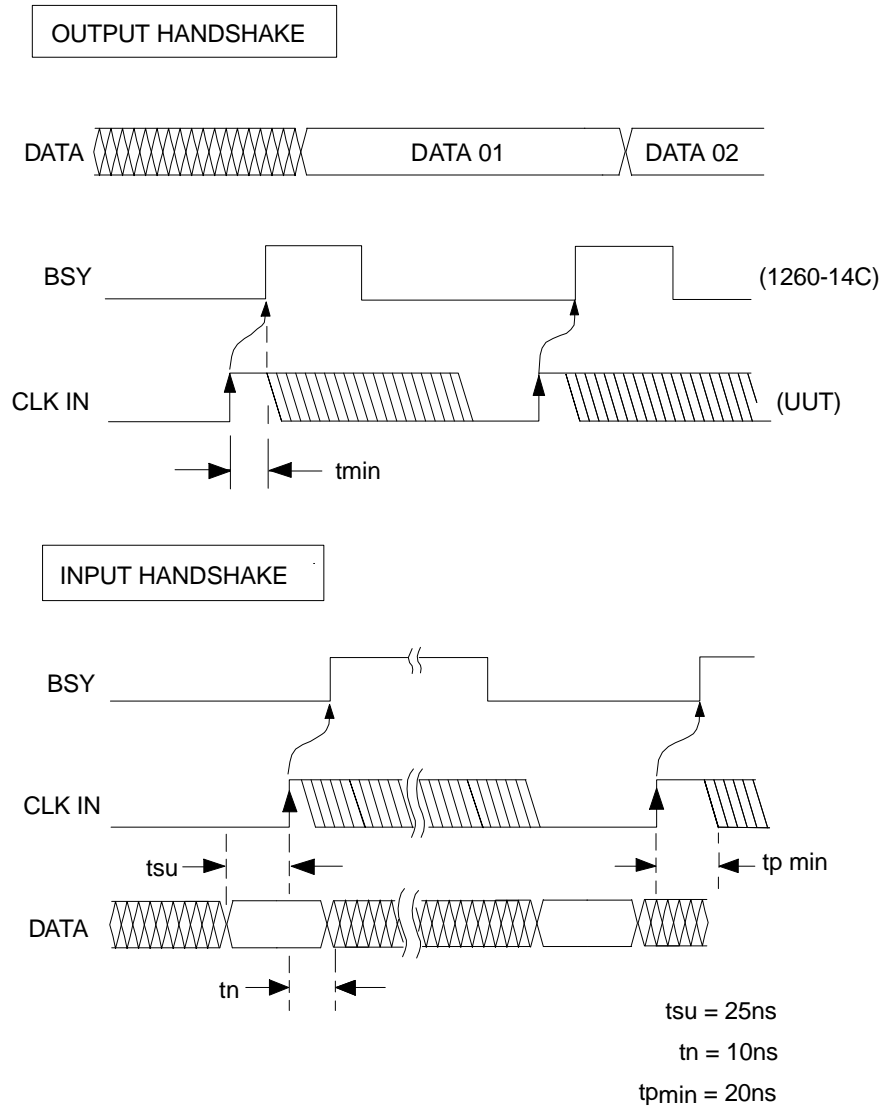

Figure 3-1, Model 1260-14C Input and Output Handshake Modes

## Module Specific Syntax

The 1260-14C Digital I/O module supports the PDATAOUT, PSETUP, READ, RESET, SETUP, and WRITE commands. The general form of the module specific syntax for the 1260-14CC Digital I/O module is:

Command address.parameters

where:

command is one of the 1260-14C module specific commands.

Address is the module address set by SW1 on the 1260-14C (1-12).

Parameters are the command specific parameters and data.

---

### **NOTE**

**The address used here is not the VXIbus defined logical address of the Master. It is a designation unique to the 1260 Series and is used by the 1260 Option 01 to identify individual 1260 modules. This switch setting is a requirement, since a single Option 01 can control multiple 1260 Series modules. This address corresponds to the binary value of the switch setting of SW1 on the switching module PCB, and can take on the values from 1 to 12.**

---

---

## Syntax Notations and Conventions

The following syntax notations and conventions are used throughout the manual:

All terms in upper case letters are used directly in the command syntax, although case is not important in the actual command string sent to the Option 01.

All items in brackets ( [ ] ) are optional.

All lower case letters within greater/less than pairs ( < > ) are to be replaced by numeric values, as specified in the syntax description.

A vertical bar ( | ) represents the "or" function, and specifies that the user must select only one of the items separated by bars.

All lines must be terminated by an ASCII line feed <LF>, EOI or both.

Write data may be in either decimal, hexadecimal, or binary format. Non-decimal numbers must be preceded with "H" for hex, or "B" for binary.

---

## Definition of Commands

### PDATAOUT Command

Syntax: PD[ATAOUT] <address>[.<ports>][,<address>[.<ports>],...]

<address>::= Module address of the 1260-14C (1-12)

<ports>::= One or more consecutive ports to return data from. A single port is specified as a decimal number from 0 to 11. A group of ports is specified as two decimal numbers from 0 to 11 separated by a hyphen, (-), with the lower numbered port to the left and the higher numbered port to the right. For example, the command string PD 1.3-5 would return values for ports 3, 4 and 5.

Description: The PDATAOUT command will cause the module specified by the logical address to return the data associated with each requested port. The format of the return data is as follows:

```
<address>. 1260-14C DIGITAL INPUT/OUTPUT MODULE
<CR><LF>
<address>. [<port>:
<data>,...]<CR><LF>
<address>.END<CR><LF>
```

where:

<address>::= A three digit module address. (001-012)

<data>::= From 0 to 256 pieces of data in either decimal, hexadecimal or binary format.

<port>::= A 2-digit number specifying the port to associate with the data that follows.

---

**NOTE**

**There is a space following the period on each line except for the line containing the END string. This allows the user to detect when the last line of a multiple line reply has occurred by looking at the fifth character of each line to see if it is a space or an ASCII "E". This convention is true for all commands returning multiple line outputs.**

---

Output data for the specified modules and ports are in the same order as requested in the command. Each port's data is preceded with the port number and a colon. The type and format of the data returned will depend on how the port is defined and the last operation performed on the port. This is determined as follows:

If the port is defined as a synchronous mode read port, the command will return the data from the most recent synchronous test, using the same data width and format that was specified when the test was defined. If the port has been defined as synchronous but no test has been run since the port was defined, no values are returned (e.g., "001. 07:").

If the port is defined as a synchronous mode write port, the command will return the most recent write data loaded for this port, using the same data width and format used to load the data. If no data is loaded, no values are returned (e.g., "001. 07:").

If the port is defined as an asynchronous port, the command will return the results of the most recent READ or WRITE command, using the same data width and format used in that command. If no READ or WRITE commands have been sent, no values are returned (e.g., "001. 07:").

**Example:**

Assume that port 0 is a synchronous mode byte-wide (8 bit) port that read in the hex values 9f, 7f, 3f and 1f during vectors 1-4 of the last synchronous test. Port 1 is a synchronous mode byte-wide port that wrote out the decimal values 21, 31, 41 and 51 during vectors 1-4 during the last synchronous test. Port 2, along with port 3, is an asynchronous word-wide (16-bit) port that was last used to read a hex 7AA6. Port 4 is an asynchronous byte-wide

port that was last used to write a binary 10101101.

The command:

PD 1.0-4

would return the following data:

```
001. 1260-14C DIGITAL INPUT/OUTPUT MODULE<CR>
    <LF>
001. 00:9F,7F,3F,1F<CR><LF>
001. 01:21,31,41,51<CR><LF>
001. 02:7AA6<CR><LF>
001. 04:10101101<CR><LF>
001.END<CR><LF>
```

## **PSETUP command**

Syntax: PS[ETUP] <address>

<address>::= Module address of the 1260-14C (1-12)

Description: This command will cause the module to return the condition of all the setup variables for the 1260-14C at the specified module address. The following is a sample output from a PSETUP command for a 1260-14C at module address 1, showing the power-up default condition for the setup variables:

```
001. 1260-14C DIGITAL INPUT/OUTPUT MODULE
001. ENABLE
001. SYNC 0
001. BUSY POS
001. CLKIN POS
001. ARM OFF
001.END
```

---

### **NOTE**

**Since the “ENABLE” command is not supported on the 1260-14C, the “ENABLE” entry in the PSETUP response is meaningless and should be ignored.**

---

## READ command

Syntax:

Byte: READ <address>.<ports>[,Y][,B | ,H]  
Word: READ <address>.<ports>,W[,B | ,H]  
Bit: READ <address>.<ports>,X<bit>[,X<bit>...]  
Fast: READ <address>.<ports>,Z[,H]

<address>::= Module address of the 1260-14C (1-12)

<ports>::= One or more consecutive ports to read from. A single port is specified as a decimal number from 0 to 11. A group of ports is specified as two decimal numbers from 0 to 11 separated by a hyphen, (-), with the least significant port to the right and the most significant port to the left. For example, the command READ 1.3-5,Y would return values for ports 3, 4 and 5.

<bit>::= The individual bit number (0-7) to read in the bit mode. The user may specify multiple bits by separating each X<bit> with commas. Bit 0 is the LSB and bit 7 the MSB.

A "B" specifies that the output format for the data is binary. Note that this format is unavailable in the fast byte mode to keep the output on a single 80-character line.

An "H" specifies that the output format for the data is hexadecimal.

A "Y" causes a byte-wide (8-bit) read of the port. This is the default if no width is specified. See Example 1 above for a sample of a byte-wide READ command.

A "W" causes a word-wide (16-bit) read of a pair of ports. Word-wide operations are specified on even-numbered ports only, and read the least significant 8 bits from the even port and the most significant 8 bits from the following odd-numbered port.

Description: This command performs an asynchronous read from a single port or a group of consecutive ports. No handshaking is required for this operation. This command will only read those ports defined as asynchronous ports. It will not read from a synchronous port. A read from a write-enabled port will return the value that the port is currently driving. As soon as the command is received, an immediate read of the specified port(s) occurs. The data for each requested port is sent to the user in the order of lowest to highest port, and with the exception of the fast mode, data is returned in a form identical to that of a PDATAOUT.

Read operations may be performed as either a bit, byte or word-

wide operation, with byte-wide being the default. In addition, on firmware revisions 18.1 and beyond, there is a byte-wide fast output mode available that reduces the output string size, significantly cutting down on the data transfer time from the 1260 Option 01 to the Slot 0 controller. Data is formatted in either decimal, hexadecimal or binary, with the default being decimal. The width and format of the output are specified as follows:

Example 1:

Assume that ports 5-11 are defined as asynchronous and are tri-stated, port 5 is sensing a 23, port 6 is sensing a 0, port 7 is sensing 127 and the user sends the following command:

```
READ 1.5-7,Y
```

The user would read back:

```
001. 1260-14C DIGITAL INPUT/OUTPUT MODULE<CR>
<LF>
001. 05: 23<CR><LF>
001. 06: 0<CR><LF>
001. 07: 127<CR><LF>
001.END<CR><LF>
```

Example 2:

Assume that all ports are defined as asynchronous and are tri-stated, port 0 is sensing a hex 1e, port 1 is sensing a hex c7, port 2 is sensing a hex d3, port 3 is sensing a hex a0 and the user sends the following command:

```
READ 1.0-2,W,H
```

The user would read back:

```
001. 1260-14C DIGITAL INPUT/OUTPUT MODULE<CR>
<LF>
001. 00: C71E<CR><LF>
001. 02: A0D3<CR><LF>
001.END<CR><LF>
```

An "X" causes a bit-wide read of the port. Any combination of the 8 bits from X0-X7 may be read simultaneously. The output will contain the status of each bit in binary format and in the same order as specified in the command.



Example 3:

Assume that ports 7-11 are defined as asynchronous and are tri-stated, port 7 is sensing a binary 10001010, port 8 is sensing a 01111101, and the user sends the following command:

```
READ 1.7-8,X7,X3,X1,X0
```

The user would read back:

```
001. 1260-14C DIGITAL INPUT/OUTPUT MODULE<CR>
    <LF>
001. 07: 1110<CR><LF>
001. 08: 0101<CR><LF>
001.END<CR><LF>
```

A "Z" causes a byte-wide (8 bit) read of the port, but instead of using the PDATAOUT format for returning the data, it uses a shorter single line output to reduce the amount of time needed to transfer the read data. It is identical to the standard byte width read with the exception that binary formatting is not available, and the output contains no header line, END line, module address or port numbers. All the output line contains is the port data separated by commas. Data is returned in least significant port to most significant port order. This type of read is only available on firmware revisions 18.1 or later.

Example 4:

Assume that ports 5-11 are defined as asynchronous and are tri-stated, port 5 is sensing a hex 7f, port 6 is sensing a hex 01, port 7 is sensing a hex c3 and the user sends the following command:

```
READ 1.5-7,Z,H
```

The user would read back:

```
7F,01,C3<CR><LF>
```

**RESET command**

Syntax: RES[ET]

Description: The RESET command resets the 1260-14C card to the power-up state. Specifically, the following attributes are programmed after the RESET command is executed:

BUSY Polarity	Positive
CLKIN Polarity	Positive
Synchronous Ports	None (SYNC 0)
Arm	Off
All Ports	Tri-stated

**SETUP ARM command**

Syntax: SE[TUP] &lt;address&gt;.AR[M],ON | OFF

&lt;address&gt;::= Module address of the 1260-14C (1-12)

Description: This command is used to arm and disarm the synchronous handshake mode. Setup data may only be modified while ARM is OFF. Synchronous data transfers may only take place when ARM is ON. Once the card is armed, any attempts to send a setup command other than a SETUP <address>.ARM,OFF will cause an error.

The completion of the last synchronous READ/WRITE operation in a test automatically sets the ARM mode to OFF. The CLKIN signal used to cause data transfers is ignored as long as ARM is OFF.

Each time the ARM is set to ON, synchronous READ/WRITE operations restart at the first location in the port's buffer. This means that if the user sets up a port to output five data items, resetting the ARM causes the first data item to be transferred at the next occurrence of the CLKIN signal. This is regardless of where in the buffer the test had been when the ARM was set to OFF. PDATAOUT commands are not recognized until ARM is OFF. The default power-up condition of ARM is OFF.

Example:

This command sets ARM mode to ON within the module at address 1.

SETUP 1.ARM,ON

## SETUP BUSY command

Syntax: SE[TUP] <address>.BU[SY],POS | NEG

<address>::= Module address of the 1260-14C (1-12)

Description: This command defines the polarity of the BUSY handshake line. Setting the polarity to POS causes the BUSY line to be set HIGH when the 1260-14C is busy processing during synchronous operation. Setting the polarity to NEG causes the BUSY line to be set LOW when the module is busy. The default power-up condition is POS.

---

### **NOTE**

**The BUSY line is only valid when synchronous operations are defined and armed. Spurious signals at other times should be ignored by the user.**

---

Example:

This command sets the polarity of the BUSY signal to negative within the module at address 2.

```
SETUP 2.BUSY,NEG
```

## SETUP CLKIN command

Syntax: SE[TUP] <address>.CL[KIN],POS | NEG

<address>::= Module address of the 1260-14C (1-12)

Description: This command defines the active edge of the CLKIN handshake signal. Setting CLKIN to POS causes the module to trigger on the positive (or rising) edge of the CLKIN signal. Setting the polarity to NEG causes the module to trigger on the negative (or falling) edge of the CLKIN signal. The default power-up condition is POS.

---

### **NOTE**

**The CLKIN line is only monitored when synchronous operations are defined and armed. Spurious signals at other times will be ignored.**

---



after a synchronous test is disarmed manually via the SETUP ARM OFF command.

Example 1:

Assume that ports 0 and 1 are defined as synchronous and the user sends the following commands:

```
SETUP 1.RD 0,Y,H,10
SETUP 1.RD 1,22
```

During the next synchronous test, port 0 would read 10 vectors worth of byte-wide information and store it in hexadecimal format. Port 1 would read 22 vectors of byte-wide information and store it in decimal format.

Read operations may be performed as either bit, byte or word width operations, with byte width being the default. Data will be formatted either in decimal, hexadecimal or binary, with the default being decimal. The width and format of the output are specified as follows:

Example 2:

Assume that ports 0-3 are synchronous ports, ports 2 and 3 were previously defined as synchronous word-wide read ports and the user sends the following commands:

```
SETUP 1.RD 0,W,5
SETUP 1.RD 2,Y,7
```

The first command would cause the module to perform a word-wide read of five vectors worth of data from ports 0 and 1 during the next synchronous test. The second command would cause a byte-wide read of 7 vectors worth of data from port 2 during the next synchronous test, and would disable port 3 from participating in subsequent tests until redefined.

An "X" specifies a bit-wide read of the port. Any combination of the 8 bits from X0-X7 may be specified, but only the selected bits are stored when the user runs the synchronous test. The buffer will contain the status of the bits requested at each vector in the same order as specified in the command. If the port was previously read using a word width, the data associated with the companion port will be cleared, and the port will be disabled in future synchronous operations until redefined.

Example 3:

Assume that port 0 is a synchronous port and the user sends the following command:

```
SETUP 1.RD 0,X5,X7,X1,10
```

This command would cause the module to perform a bit-wide read of bits 5, 7 and 1 for ten vector on port 0 during the next synchronous test.

## SETUP SYNC command

Syntax:       SE[TUP] <address> .SY[NC],<number of ports>

<address>::= Module address of the 1260-14C (1-12)

<number of ports>::= Number of ports to make synchronous (0-12)

Description:   This command specifies the number of ports that will have the synchronous mode enabled. Note that the user may not specify which ports are synchronous and which are asynchronous. Instead, the synchronous ports are always grouped together starting at port 0; i.e., the first synchronous port is always port 0; the second is always port 1, etc.

Example:

Assume the user sends the following command:

```
SETUP 1.SYNC,5
```

This would cause the digital I/O card with the module address of 1 to define the 5 ports from port 0 to port 4 as synchronous ports. The remaining 7 ports from port 5 to port 11 would become asynchronous.

On power-up, the synchronous mode is disabled for all ports. When the SYNC command is given, those ports that change configuration from asynchronous to synchronous, or vice versa, are re-initialized. This causes any old format, mode, or read/write data to be removed. Consequently, all new synchronous ports should be programmed with a SETUP <address>.RD or SETUP <address>.WR command before they are used in synchronous operations.

Only those ports defined as synchronous may perform data transfers utilizing the CLKIN and BUSY handshake lines.

The asynchronous WRITE command will work normally on a synchronous port, but the READ command will not. This allows

the user to preset the value of the port prior to the beginning synchronous operations. Note that this may only be done while the synchronous mode is not armed.

## SETUP WR command

Syntax:      Byte: SE[TUP] <address>.WR,<port>[,Y][,  
                  <byte>,...,<byte>]  
              Word: SE[TUP] <address>.WR,<port>[,W][,  
                  <word>,...,<word>]  
              Bit:  SE[TUP] <address>.WR,<port>[,X][,  
                  <bits>;...;<bits>]

<address>::= Module address of the 1260-14C (1-12)

<port>::=      Synchronous port number that is being  
                  defined (0-11)

<byte>::=      An 8 bit value specified as either decimal  
                  format (0-255), hexadecimal format (H0-HFF) or binary  
                  format (B0-B1111111). Note that the "H" is required in  
                  front of hex values and the "B" is required in front of binary  
                  values.

<word>::=      A 16-bit value specified in either decimal  
                  format (0-65535), hexadecimal format (H0-HFFFF) or  
                  binary format (B0-B111111111111111). Note that the "H"  
                  is required in front of hex values and the "B" is required in  
                  front of binary values.

<bits>::=      Specifies up to eight single bit transitions in  
                  the form Lx|Hx,...Lx|Hx where x specifies which bit number  
                  to write high (Hx) or low (Lx), and x may take the values  
                  from 0-7. For example, SETUP 5.WR 1,X,L1,L3;H0,H1  
                  would cause bits 1 and 3 in port 1 to go low in vector 1  
                  followed by bits 0 and 1 going high in vector 2.

A "B" specifies that the output format for the data is binary. Note that this format is unavailable in the fast byte mode to keep the output on a single 80-character line.

A "H" specifies that the output format for the data is hexadecimal.

A "Y" causes a byte-wide (8 bit) read of the port. This is the default if no width is specified. See Example 1 above for a sample of a byte-wide READ command.

A "W" causes a word-wide (16-bit) read for a pair of ports. Word-wide operations are specified on even-numbered ports only, and read the least significant 8-bits from the even port and the most significant 8-bits from the following odd-numbered port.

**Description:** This command sets up a single synchronous port to perform a buffered write operation. Up to 256 data vectors can be set up ahead of time in the port's buffer. Once a synchronous test is armed, data from the buffer is clocked out of the port by each active edge of CLKIN until either the last data item for each synchronous port has been clocked, automatically disarming the test, or the user disarms the test manually using the SETUP ARM,OFF command. The last value on the port will remain there until either another synchronous test is run, the user performs an asynchronous WRITE on the port, or the user resets the module. It should be noted that it is the user's responsibility to ensure that the appropriate ports are write-enabled before starting the synchronous test.

Write commands may be specified either as bit, byte or word-wide operations. When a width change is requested by using either the "W", "X" or "Y" width designator, the port's buffer is cleared of all previous data and the new data is loaded starting at vector 1. If there is no width designator, the port remains in its current mode, and the new data is appended to the existing data in the buffer for up to a maximum of 256 vectors of data. This means that multiple statements may be used to load a given port's buffer by specifying a width for the first SETUP WR statement, and not specifying a width for subsequent statements.

Example 1:

Assume the user sends the following three statements to the module:

```
SETUP 1.WR 0,Y,7,15,23
```

```
SETUP 1.WR 0,255
```

```
SETUP 1.WR 0,100
```

The first SETUP statement would set up port 0 to perform byte-wide operations and would clear the port 0 buffer of any previous values. It would then load a 7 in vector 1, a 15 in vector 2, and a 23 in vector 3. The second SETUP statement would leave the buffer intact, and would load a 255 in vector 4. The final SETUP statement would load a 100 in vector 5. Once the test was armed, port 0 would be actively driving a 7 after the first clock, a 15 after the second, etc. and would end the test driving a 100.

The data that is loaded in the buffer remains there until either the port is re-initialized by a SETUP WR or a WRITE command, the port is redefined to be a read port, the port is redefined to be an asynchronous port, or the unit is reset. This means that it is possible to arm and run a test multiple times without having to reload the write data.

Bit, byte and word-wide operations cannot be mixed in a port. Only



one width may be active at a time and is specified as follows:

A "Y" specifies a byte-wide (8-bit) write to a port. If the port was previously defined using a word width, the data associated with the companion port will be cleared, and the port will be disabled in future synchronous operations until redefined. When a port is first defined as synchronous, it defaults to byte-wide operations, so it is only necessary to specify a byte width if the user is changing from a different width, or wishes to clear the buffer. See Example 1 above for a sample of a byte-wide synchronous write setup.

A "W" specifies a word-wide (16 bit) write to a pair of ports. Word-wide operations are specified on even-numbered ports only, and place the least significant 8 bits in the even port and the most significant 8 bits in the following odd-numbered port. Word sized operations may not be mixed with bit or byte operations in either the even or odd port. If either the even or the odd port is redefined as a byte-wide or a bit-wide port, both ports will have their buffers cleared and the matching odd or even companion port will be disabled in future synchronous operations until redefined.

Example 2:

Assume that ports 0-3 are synchronous ports, ports 2 and 3 were previously defined as synchronous word-wide write ports and the user sends the following commands:

```
SETUP 1.WR 0,W,H5F01,H6F02,H7F03
                                SETUP 1.WR 2,Y,16,8,4,2,1
```

The first command would clear the buffers for ports 0 and 1, and would cause the module to perform a word wide write of three vectors to ports 0 and 1 during the next synchronous test, finishing the test with the value of hex 03 in port 0 and hex 7F in port 1. The second command would clear the buffers for ports 2 and 3 and would cause a byte-wide write of five vectors to port 2 during the next synchronous test, finishing the test with a value of 1 in port 2. Port 3 would be disabled from participating in subsequent tests until redefined.

An "X" specifies a bit-wide write to a port. Any of the 8 bits from 0-7 may be set to 0 (Low) or 1 (High) by using the form Lx or Hx, where x is the bit to modify. Multiple bits may be modified by separating the bit transitions with commas. Multiple vectors may be set up by separating the changes for each vector with semicolons. Bits that are not modified remain in their previous states. If the port was previously defined using a word width, the data associated with the companion port will be cleared, and the port will be disabled in future synchronous operations until redefined.

## Example 3:

Assume the user sends the following two statements to the module and the current value of port 0 is a binary 00000000:

```
SETUP 1.WR 0,X,H3;H1,L3;H5,H7
                                SETUP 1.WR 0,L1,L7
```

The first SETUP statement will first clear the buffer for port 0, then specify that bit 3 will go high in vector 1, bit 1 will go high and bit 3 will go low in vector 2, and bits 5 and 7 will go high in vector 3. The second SETUP statement will leave the buffer intact and will specify that in vector 4, bits 1 and 7 will go low. Once the test is armed, port 0 would be actively driving a binary 00001000 after the first clock, a 00000010 after the second, a 10100010 after the third and a 00100000 after the last clock.

**WRITE command**

Syntax: Byte: WR[ITE] <address>.<ports>[,Y][,<byte>,...,<byte>]

Word: WR[ITE] <address>.<ports>[,W][,<word>,...,<word>]

Bit: WR[ITE] <address>.<ports>[,X][,<bits>;.....;<bits>]

<address>::= Module address of the 1260-14C (1-12)

<ports>::= One or more consecutive ports to write to. A single port is specified as a decimal number from 0 to 11. A group of ports is specified as two decimal numbers from 0 to 11 separated by a hyphen, (-), with the least significant port to the right and the most significant port to the left. For example, the command WR 1.3-5,Y,0,1,2 would write a 0 in port 3, a one in port 4 and a 2 in port 5. Data may be specified in decimal, hexadecimal or binary.

<byte>::= An 8-bit value specified as either decimal format (0-255), hexadecimal format (H0-HFF) or binary format (B0-B11111111). Note that the "H" is required in front of hex values and the "B" is required in front of binary values.

<word>::= A 16-bit value specified in either decimal format (0-65535), hexadecimal format (H0-HFFFF) or binary format (B0-B1111111111111111). Note that the "H" is required in front of hex values and the "B" is required in front of binary values.

<bits>::= Specifies up to eight single bit transitions in

the form Lx|Hx,...Lx|Hx where x specifies which bit number to write high (Hx) or low (Lx), and x may take the values from 0-7. For example, WR 1.1-2,X,L1,L3;H0,H1 would cause bits 1 and 3 to go low in port 1 and bits 0 and 1 to go high in port 2.

A "B" specifies that the output format for the data is binary. Note that this format is unavailable in the fast byte mode to keep the output on a single 80-character line.

A "H" specifies that the output format for the data is hexadecimal.

A "Y" causes a byte-wide (8 bit) read of the port. This is the default if no width is specified. See Example 1 above for a sample of a byte-wide READ command.

A "W" causes a word-wide (16 bit) read for a pair of ports. Word-wide operations are specified on even-numbered ports only, and read the least significant 8 bits from the even port and the most significant 8 bits from the following odd-numbered port.

Description: This command performs an asynchronous write to a single port or a group of consecutive ports. No handshaking is required for this operation. The command is primarily used to write to asynchronous ports, but may be used to preset synchronous ports to a known value before starting synchronous operations.

---

**NOTE**

**Care should be used not to change the width when writing to a synchronous port if the port has already had its width defined and data loaded into the buffer. In this case, the user should not specify a width, and should format the WRITE data in the same size that the synchronous port was defined at. Failure to do so will cause the port to change its width designation, and will clear the data in the buffer.**

---

As soon as the command is received, an immediate write to the specified ports occurs. A port may be written to when tri-stated, but the value will not become present on the port until after it is write-enabled. The data is written one data item per port, and the number of ports must match the number of data items. The first data item corresponds to the lowest significant port and the last data item corresponds to the highest significant port.

Example 1:

Assume that ports 5-11 are defined as asynchronous and the user sends the following command:

```
WR 1.5-7,Y,23,0,127
```

At the end of command execution, port 5 would be actively driving a 23, port 6 would be driving 0 and port 7 would be driving 127.

Write operations may be performed as either a bit, byte or word-wide operation. If no width is specified, it remains unchanged from its previous setting, and the data must be specified in the same form as used in the most recent WRITE or SETUP WR statement for each port. If no width has ever been specified, the default is byte-wide. Bit, byte and word-wide operations cannot be mixed in a port. Only one width is active at a time and is specified as follows.

A "Y" causes a byte-wide (8 bit) write to the ports. When writing to a synchronous port that was previously defined or written to using a word width, the data buffer associated with the companion port will be cleared and the port will be disabled in future synchronous operations until it is redefined. When a port is first defined as synchronous or asynchronous, it defaults to byte-wide operations, so it is only necessary to specify the byte width if the user is changing from a different width, or wishes to clear the synchronous write buffer. See Example 1 above for a sample of a

byte-wide asynchronous write.

A "W" causes a word-wide (16 bit) write to pairs of ports. Word-wide operations are specified on even-numbered ports only, and place the least significant 8 bits in the even port and the most significant 8 bits in the following odd-numbered port. Word-wide operations may not be mixed with bit or byte-wide operations in either the even or odd port.

Example 2:

Assume that ports 5-11 are defined as asynchronous and the user sends the following command:

```
WR 1.8,W,H23A7
```

At the end of command execution, port 8 would be actively driving a hex 23 and port 9 would be driving hex A7.

An "X" specifies a bit-wide write to the ports. Any of the 8 bits within a port may be set to 0 (Low) or 1 (High) by using the form Lx or Hx, where x is the bit (0-7) to modify within the byte. Multiple bits within a port may be modified by separating the bit transitions with commas. Multiple ports may be modified by separating the changes for each port with semicolons. Bits that are not modified remain in their previous states. When writing to a synchronous port that was previously defined or written to using a word width, the data buffer associated with the companion port will be cleared and the port will be disabled in future synchronous operations until it is redefined.

Example 3:

Assume that all ports are asynchronous, the current value of port 0 and port 1 is a binary 00000000 and the user sends the following statements to the module:

```
WR 1.0-1,X,H3;H1,H7
```

```
WR 1.0-1,L3,H5;L1,H6
```

After the execution of the first command, port 0 would be actively driving a binary 00001000 and port 1 would be driving a 10000010. After the second command, port 0 would be driving a 00100000 and port 2 would be driving a 11000000. Note that in the second command, there was no width specified since it was not required.

---

## Synchronous Mode Example

The following is an example of an 8-vector synchronous read/write operation using a 1260-14C at address 1:

1. SE 1.SY,2<CR><LF>                      Sets up ports 0 and 1 for SYNC mode; ports 2-11 will be in ASYNC mode.
2. SE 1.RD 0,8<CR><LF>                      Tells the module to read data into first eight buffer locations of port 0 when clocked.
3. SE 1.WR 1,Y,1,2,3,4<CR><LF>              Sets port 1 into the byte mode and loads write data into its first four buffer locations.
4. SE 1.WR 1,5,6,7,8<CR><LF>              Loads write data into the next four buffer locations of port 1.
5. WR 1.1,0<CR><LF>                      Presets the value of port 1 to zero.

Now the 1260-14C has the write data in the first eight buffer locations for port 1.

6. SE 1.AR, ON<CR><LF>                      Enable SYNC handshake of READ/WRITE.

Eight handshakes occur using the CLKIN and BUSY lines, each one causing a READ/WRITE to/from ports 0/1 for the eight programmed buffer locations. The eighth clock input causes the 1260-14C to disarm and stops all handshaking until the unit is rearmed.

7. PD 1.0<CR><LF>                      Reads the data from the 1260-14C.

Repeat Steps 3-7 to reprogram and run using a new set of WRITE data, or repeat Steps 5-7 to re-execute the same test.

## Chapter 4

# DRAWINGS

---

407164	Final Assy, 1260-14C	4-3
405069	PCB Assy, 1260-14C	4-4
405069	Schematic, 1260-14C	4-5
407179-001	PCB Cable Assy, 50-Pin	4-24
407179-002	PCB Cable Assy, 50-Pin	4-24
407180-001	PCB Cable Assy, 60-Pin	4-25
407180-002	PCB Cable Assy, 60-Pin	4-25
404970	Cable Assy, J101	4-26
404971	Cable Assy, J102	4-27
404973	Cable Assy, J103	4-28
404972	Cable Assy, J104	4-29

This page was intentionally left blank



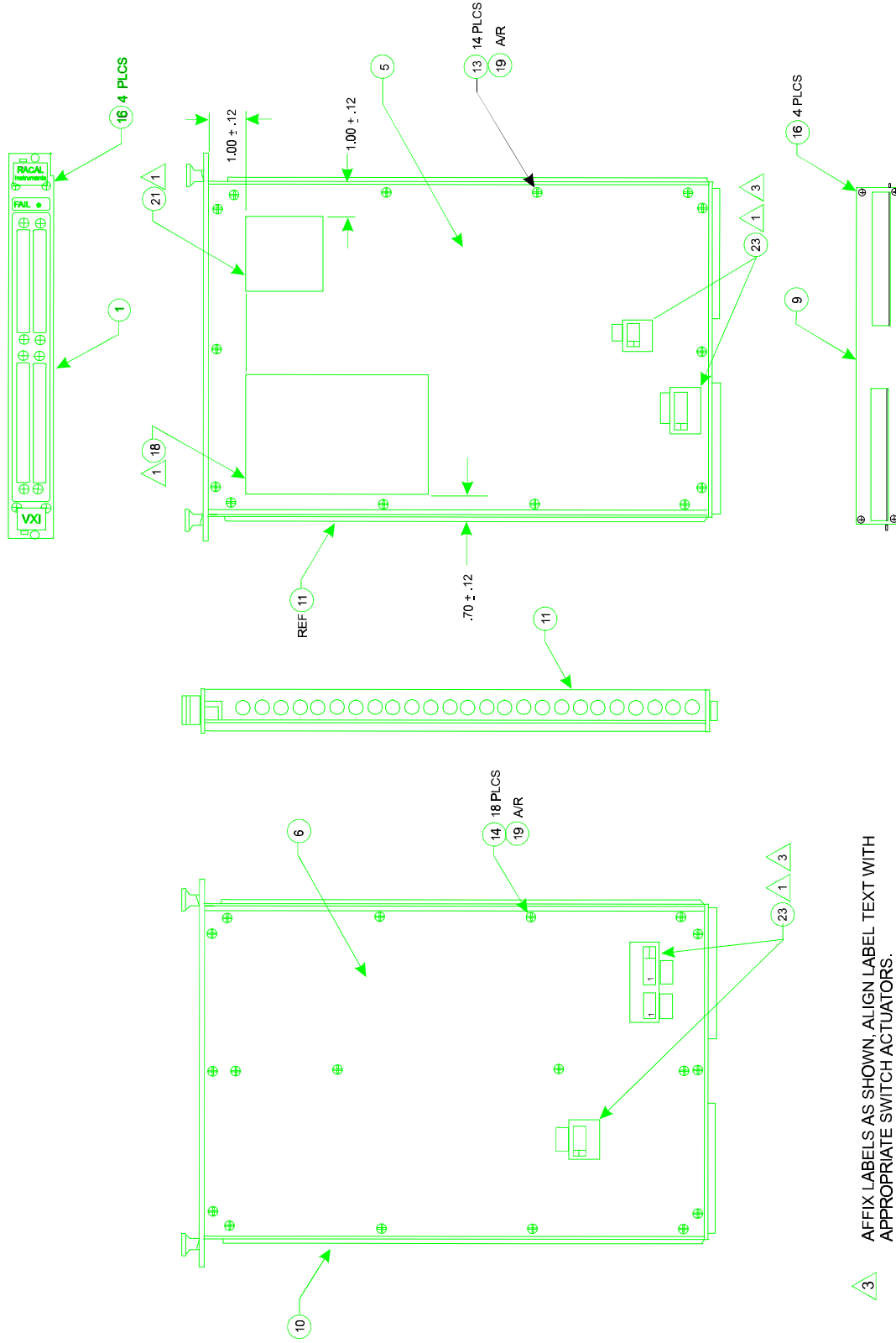

- 3 AFFIX LABELS AS SHOWN. ALIGN LABEL TEXT WITH APPROPRIATE SWITCH ACTUATORS.
- 2 INCLUDE ITEM 3 (SHIPPING KIT) IN BOX WITH ASSY.
- 1 LOCATE LABELS WHERE SHOWN.

NOTES: UNLESS OTHERWISE SPECIFIED

**PROPRIETARY NOTICE**  
 THIS DOCUMENT AND THE TECHNICAL DATA HEREIN DISCLOSED ARE PROPRIETARY TO RACAL INSTRUMENTS, INC. NO PART OF THIS DOCUMENT OR THE INFORMATION HEREIN SHALL BE REPRODUCED, COPIED, OR TRANSMITTED IN ANY FORM OR BY ANY MEANS, ELECTRONIC OR MECHANICAL, INCLUDING PHOTOCOPYING, RECORDING, OR BY ANY INFORMATION STORAGE AND RETRIEVAL SYSTEM, WITHOUT THE WRITTEN PERMISSION OF RACAL INSTRUMENTS, INC. THIS DOCUMENT IS THE PROPERTY OF RACAL INSTRUMENTS, INC. AND IS LOANED TO YOU FOR YOUR USE ONLY. IT IS NOT TO BE DISTRIBUTED OR REPRODUCED IN ANY MANNER WITHOUT THE WRITTEN PERMISSION OF RACAL INSTRUMENTS, INC. THE INFORMATION HEREIN HAS BEEN OBTAINED FROM A COMPETITIVE SOURCE AND IS FOR YOUR INFORMATION ONLY. IT IS NOT TO BE USED FOR ANY PURPOSES OF ENGINEERING OR DESIGN, OR FOR ANY OTHER PURPOSES, WITHOUT THE SPECIFIC PERMISSION OF RACAL INSTRUMENTS, INC.

<b>RACAL Instruments, Inc.</b> 4 Goodyear St., Irvine, Ca 92718-2002	
TITLE <b>FINAL ASSY, 1260-14C</b>	
SIZE <b>D</b>	DOCUMENT NO. <b>407164</b>
SCALE	REV. <b>A</b>
SHEET 1 OF 2	



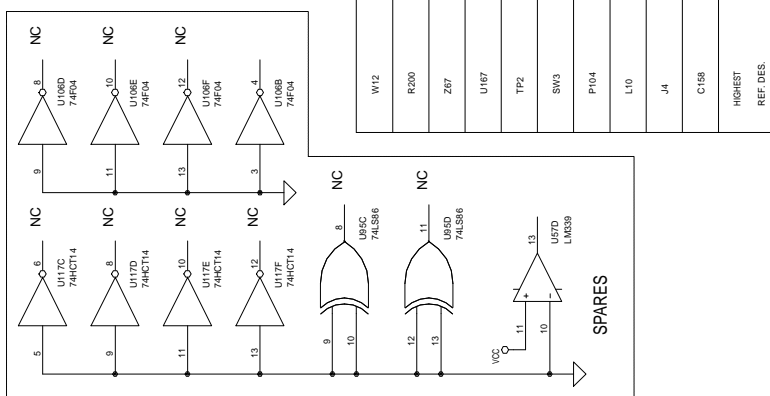

REF. DES.	IC TYPE	IC PIN NO.	+5V PIN NO.	GROUND PIN NO.
U71,72	74HC1263	16		8
U70	231152 (16L80)	20		10
U64,65,106	74F04	14		7
U57,131-154	LM339	3		12
U56	74HC105	16		8
U54,55	74LS138	16		8
U53	231153 (16R-4)	20		10
U52	231154 (22V10H)	28		14
U51	26LS31	16		8
U49,50	26LS32	16		8
U4,8,12,16,20,24, U38,32,36,40,44,48,60, U107,109	74HC168	16		8
U2,6,10,14,18,22, U36,30,34,38,42,46, U97,99	74HC1273	20		10
U1,5,9,13,17,21,25, U29,33,37,41,45,61, U82,100,102	74HC164	14	+5V	7
REF. DES.	IC TYPE	IC PIN NO.	+5V PIN NO.	GROUND PIN NO.

REF. DES.	IC TYPE	IC PIN NO.	+5V PIN NO.	GROUND PIN NO.
U156-167	74HC240	20		10
U119-130	74HC1652	24		12
U118	231237 (22V10H)	28		14
U117	74HC114	14		7
U103	231238 (20RA10)	28		15
U96,104,105,114	74HC1244	20		10
U95	74LS86	14		7
U92	231239 (22V10H)	28		14
U89-91	UDN8933		+5V	9
REF. DES.	IC TYPE	IC PIN NO.	+5V PIN NO.	GROUND PIN NO.

IC POWER AND GROUND CONNECTIONS

IC POWER AND GROUND CONNECTIONS

3. RESISTOR VALUES ARE IN OHMS, 1% 6W, 4-5%.

2. RESISTOR NETWORKS ARE IN OHMS.

1. CAPACITOR VALUES ARE IN MICROFARADS, 50V, +20% UNLESS OTHERWISE SPECIFIED.

CAD FILENAME & CURRENT REV/LTR	FOR SHEETS 1 THRU 19.
5089P11.RVA	
5089P12.RVA	
5089P13.RVA	
5089P14.RVA	
5089P15.RVA	
5089P16.RVA	
5089P17.RVA	
5089P18.RVA	
5089P19.RVA	
5089P10.RVA	

PROPRIETARY NOTICE  
 THIS DOCUMENT IS THE PROPERTY OF RACAL INSTRUMENTS, INC. AND IS NOT TO BE REPRODUCED OR TRANSMITTED IN ANY FORM OR BY ANY MEANS, ELECTRONIC OR MECHANICAL, INCLUDING PHOTOCOPYING, RECORDING, OR BY ANY INFORMATION STORAGE AND RETRIEVAL SYSTEM, WITHOUT THE WRITTEN PERMISSION OF RACAL INSTRUMENTS, INC. THIS DOCUMENT IS UNCLASSIFIED AND IS NOT SUBJECT TO EXPORT CONTROL RESTRICTIONS. IT IS THE POLICY OF RACAL INSTRUMENTS, INC. TO MAKE THIS DOCUMENT AVAILABLE TO ALL RACAL EMPLOYEES AND TO ALL RACAL CUSTOMERS AND SUPPLIERS. IT IS THE POLICY OF RACAL INSTRUMENTS, INC. TO MAKE THIS DOCUMENT AVAILABLE TO ALL RACAL EMPLOYEES AND TO ALL RACAL CUSTOMERS AND SUPPLIERS.

RACAL Instruments, Inc. 4 Goodyear St., Irvine, Ca. 92718-2002	
TITLE	SCHEM, 1260-14C
DESIGN NO.	D121783
DATE	4/30/89
REV.	A
SHEET	1 OF 19

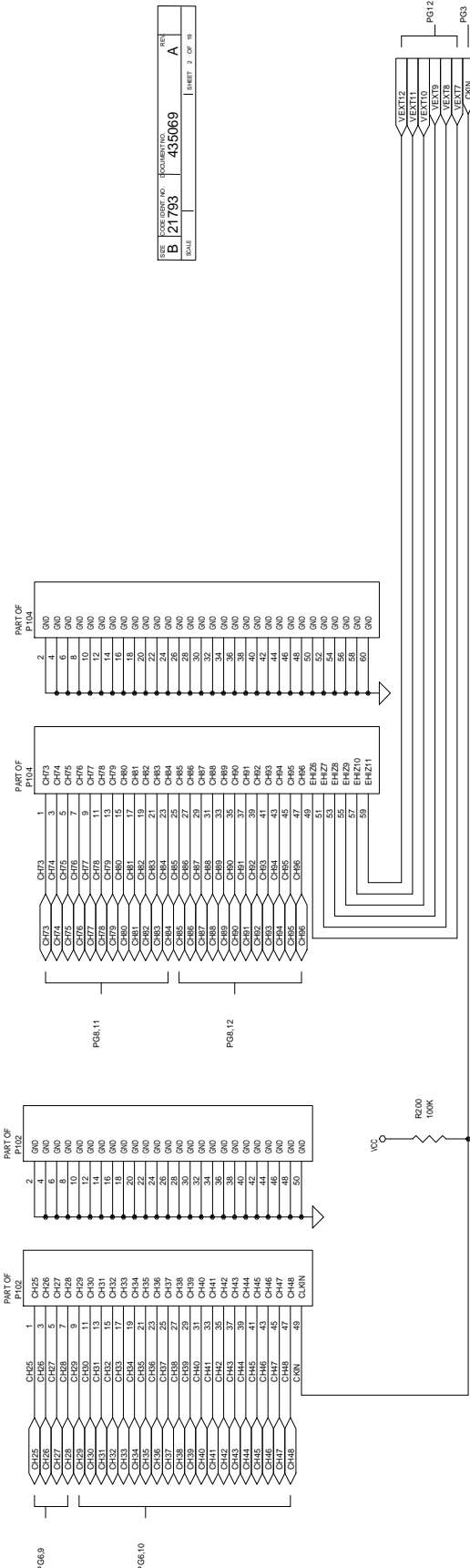
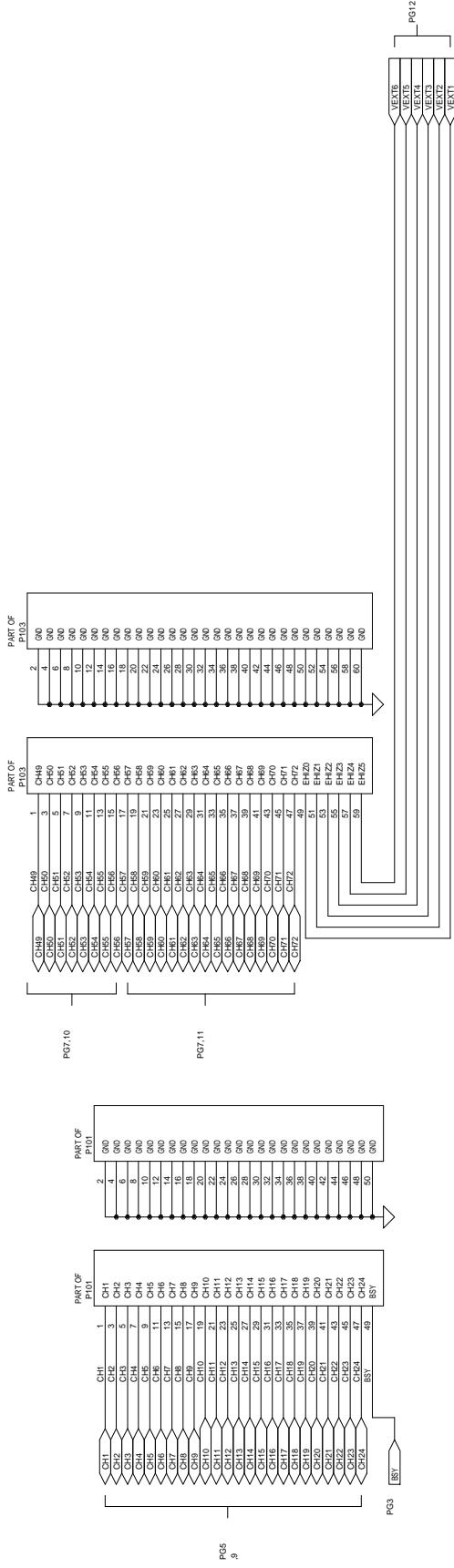

REV. A  
 DOCUMENT NO. 435069  
 B 21793  
 SCALE

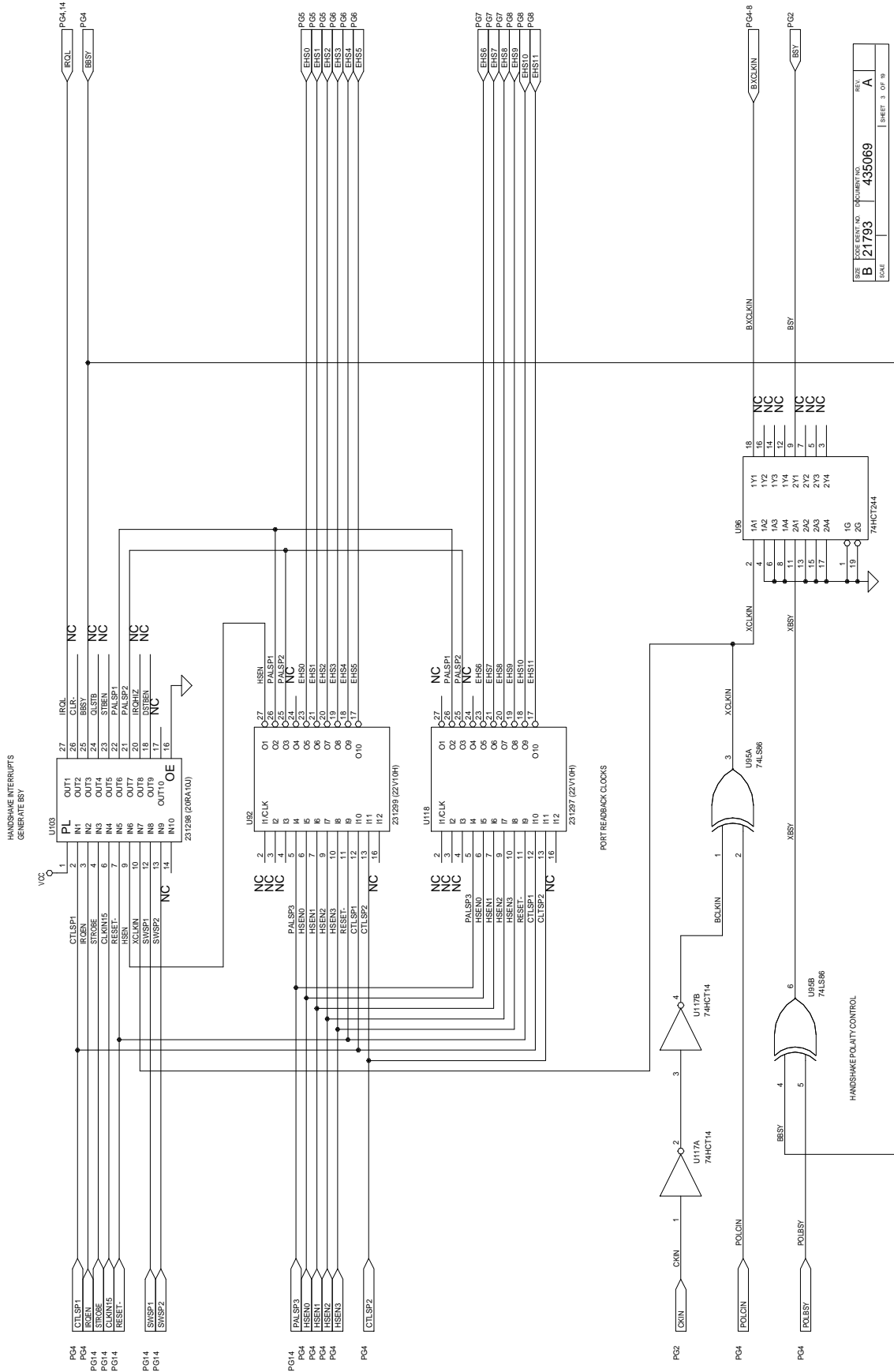

SIZE	SCALE	DATE	REV	REV
B	1:1	2/17/93	435069	A
DOCUMENT NO.			SHEET 3 OF 9	

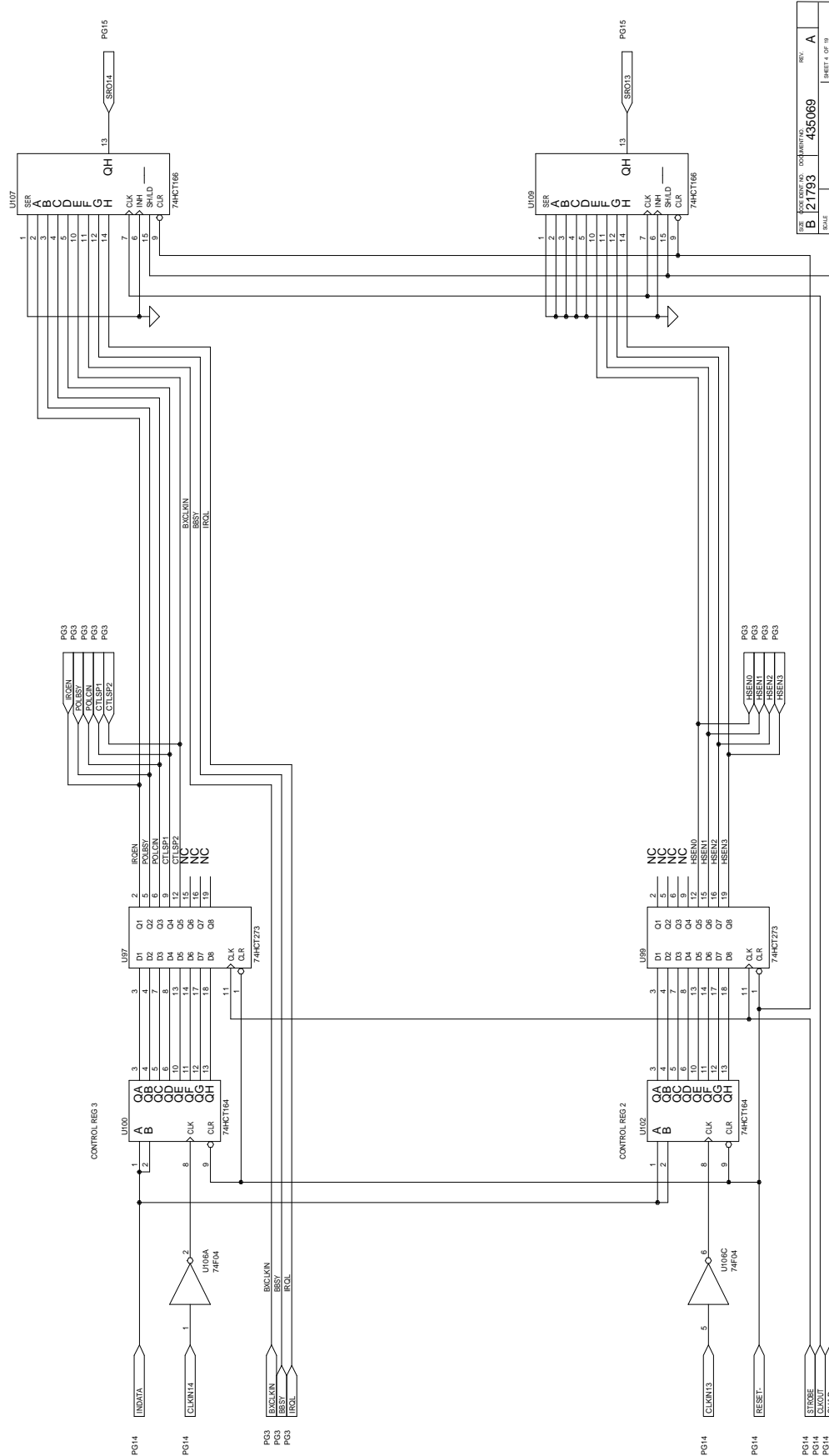

FILE	USER NAME	DATE	SCALE	REV
B	21793	04/28/14	435069	A
				SHEET 4 OF 19

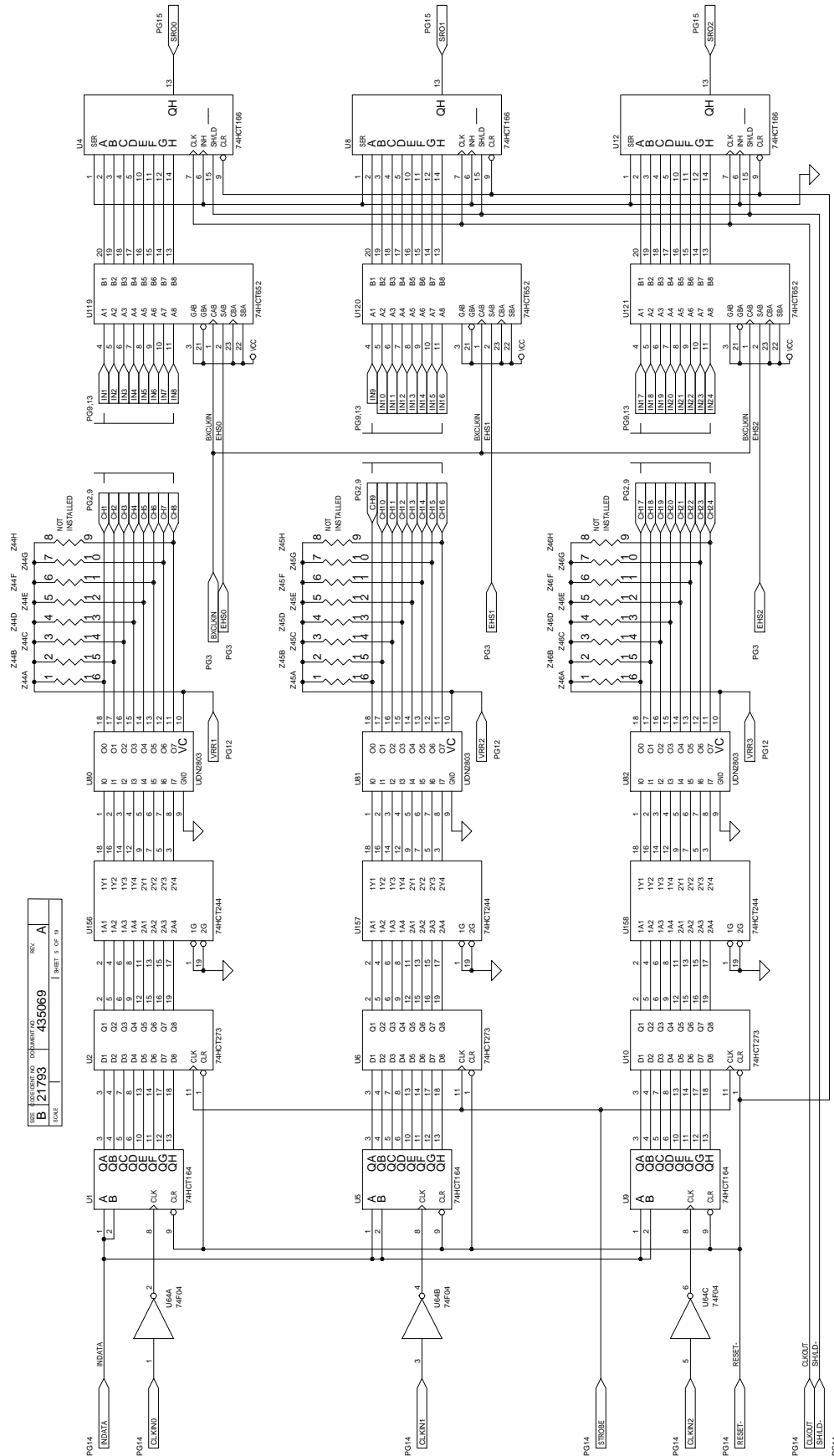

REV. A
435069
21793
DATE
DESIGNED BY
DRAWN BY
CHECKED BY
PG 14
PG 15
PG 16
PG 17
PG 18
PG 19
PG 20
PG 21
PG 22
PG 23
PG 24
PG 25
PG 26
PG 27
PG 28
PG 29
PG 30
PG 31
PG 32
PG 33
PG 34
PG 35
PG 36
PG 37
PG 38
PG 39
PG 40
PG 41
PG 42
PG 43
PG 44
PG 45
PG 46
PG 47
PG 48
PG 49
PG 50
PG 51
PG 52
PG 53
PG 54
PG 55
PG 56
PG 57
PG 58
PG 59
PG 60
PG 61
PG 62
PG 63
PG 64
PG 65
PG 66
PG 67
PG 68
PG 69
PG 70
PG 71
PG 72
PG 73
PG 74
PG 75
PG 76
PG 77
PG 78
PG 79
PG 80
PG 81
PG 82
PG 83
PG 84
PG 85
PG 86
PG 87
PG 88
PG 89
PG 90
PG 91
PG 92
PG 93
PG 94
PG 95
PG 96
PG 97
PG 98
PG 99
PG 100

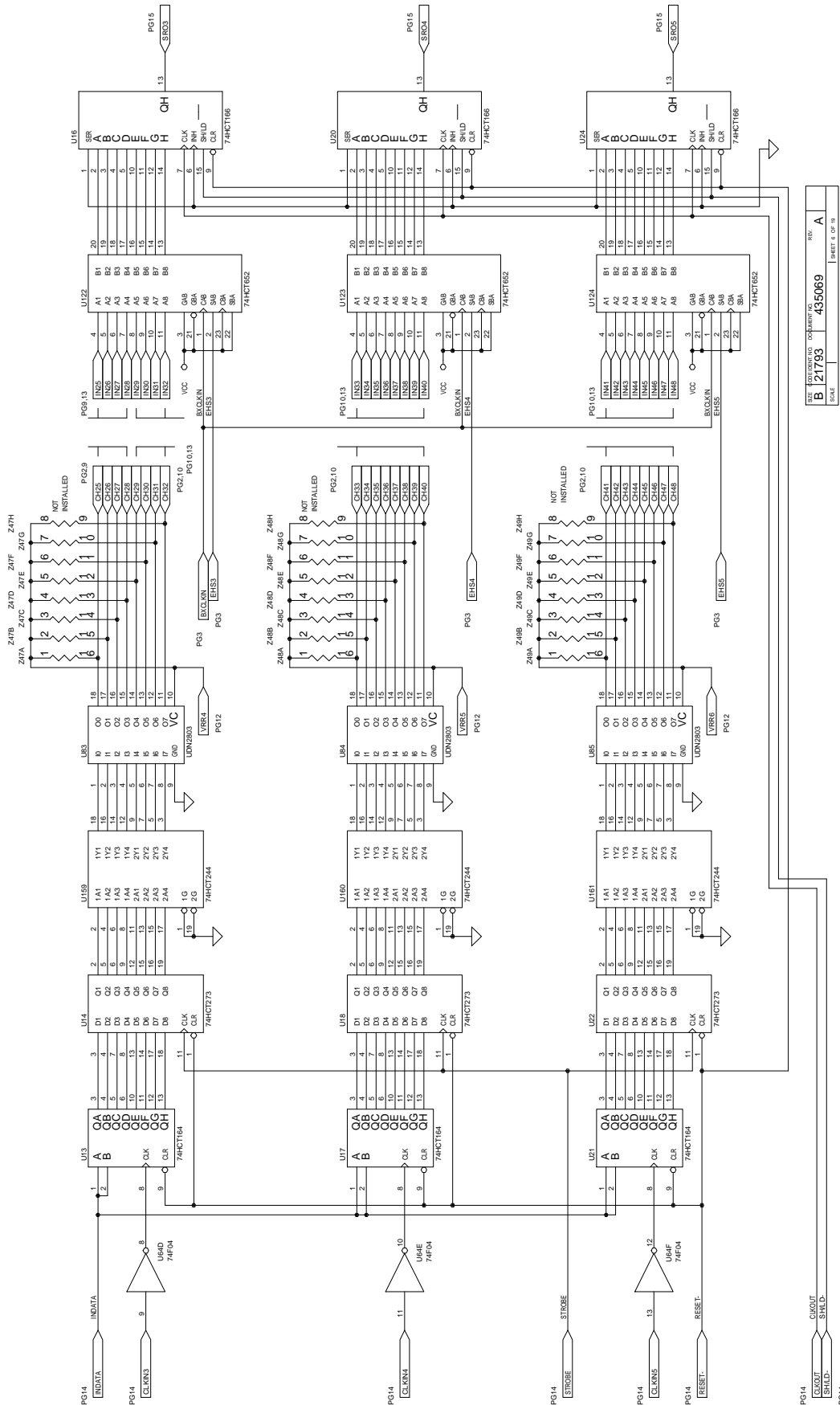

REV	A
DATE	04/01/90
DESIGN NO.	21793
WORKPART NO.	435069
SCALE	
SHEET 6 OF 19	



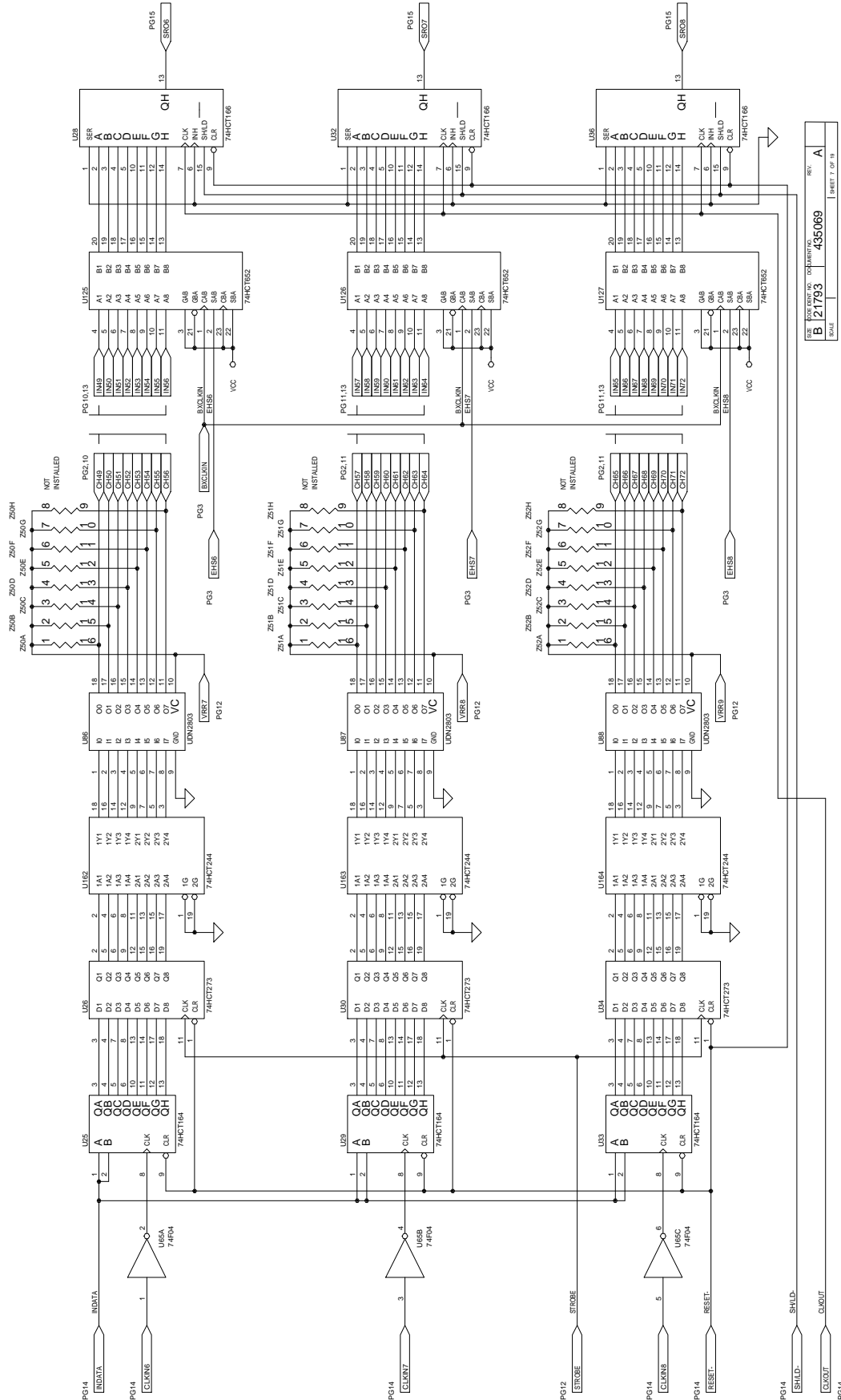

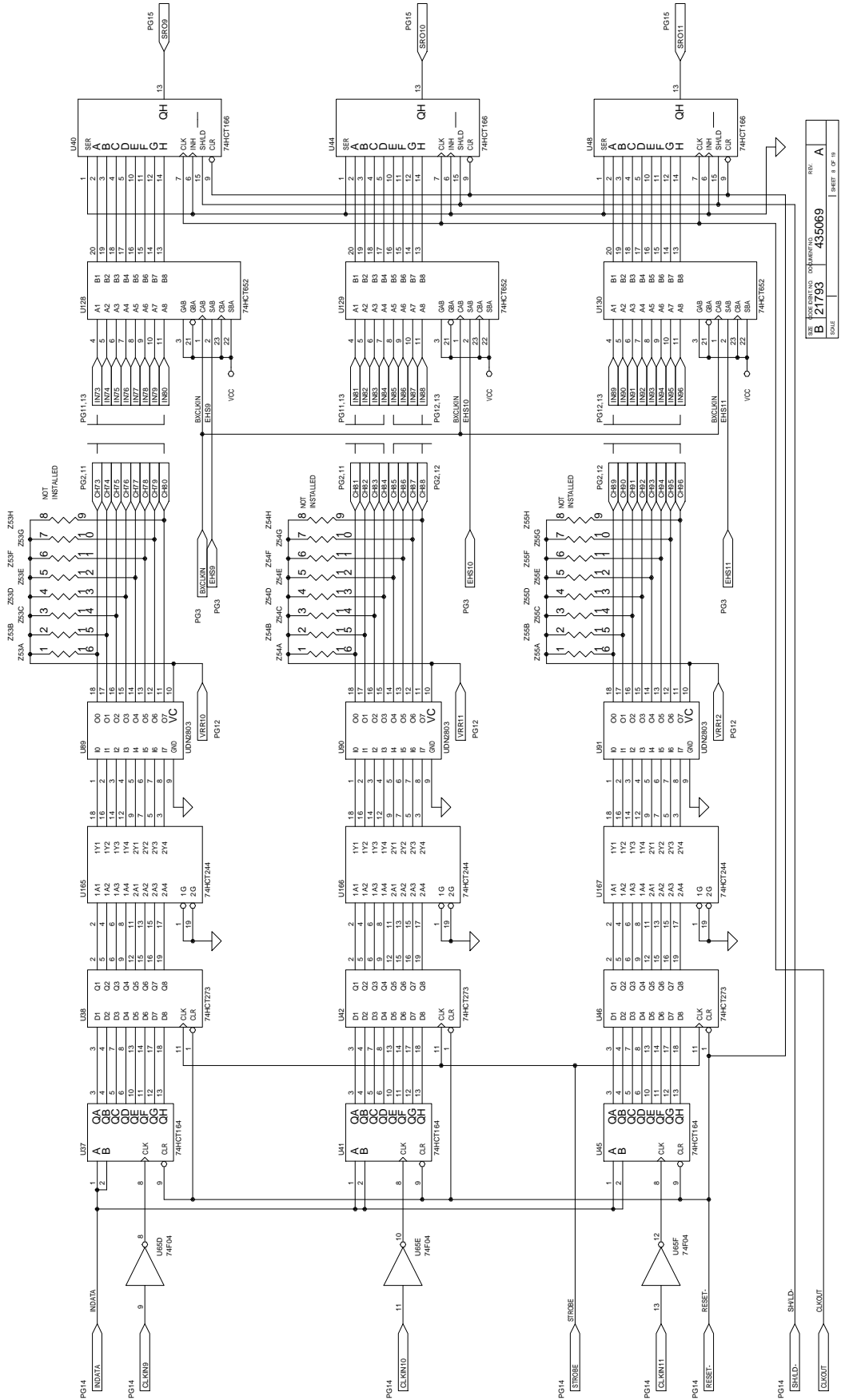

REV: A  
 DATE: 12/17/83  
 DRAWING NO: 435069  
 SHEET # OF 11

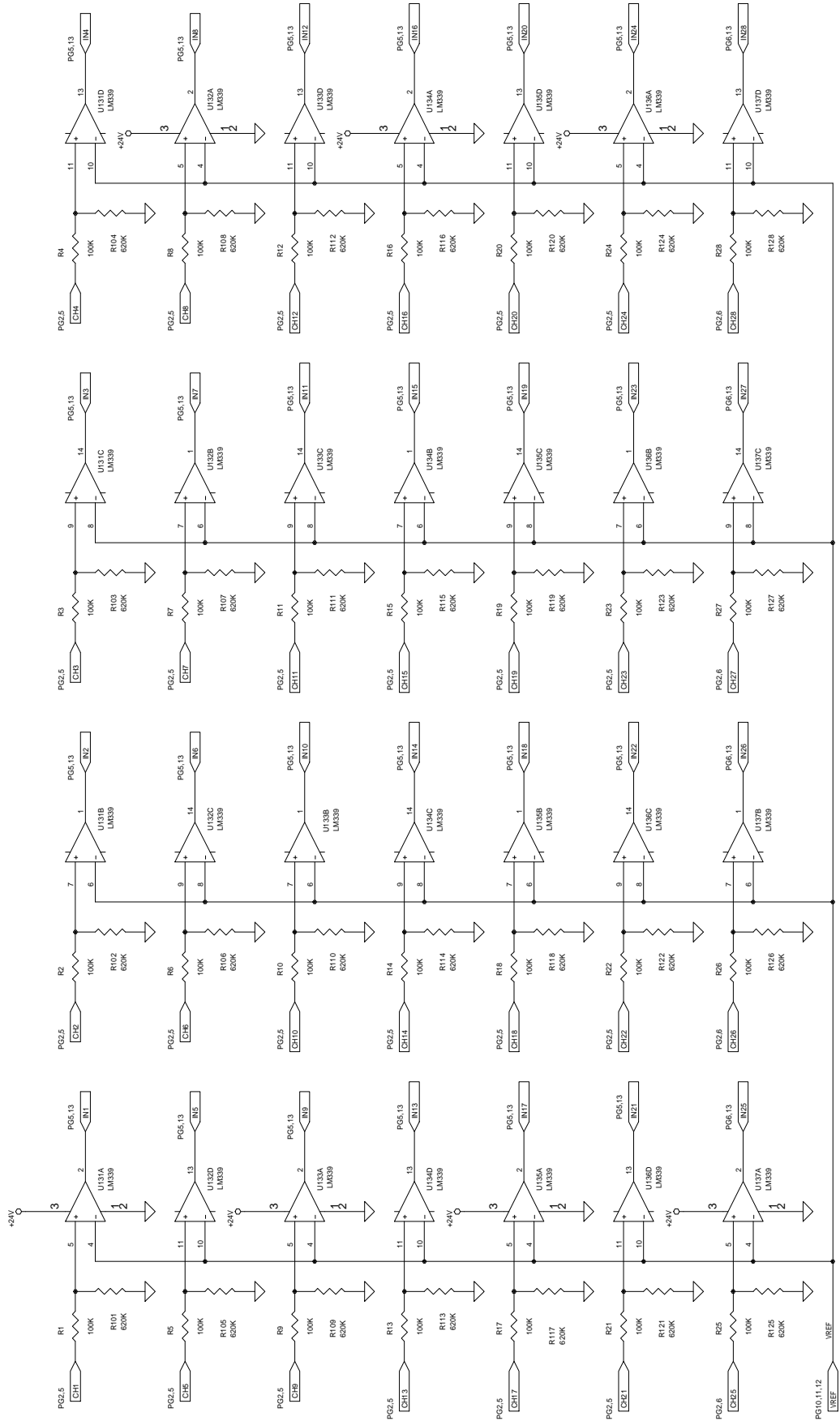

SIZE	BOOK SHEET NO.	DOCUMENT NO.	REV.
B	21793	435069	A
SCALE			SHEET 9 OF 19

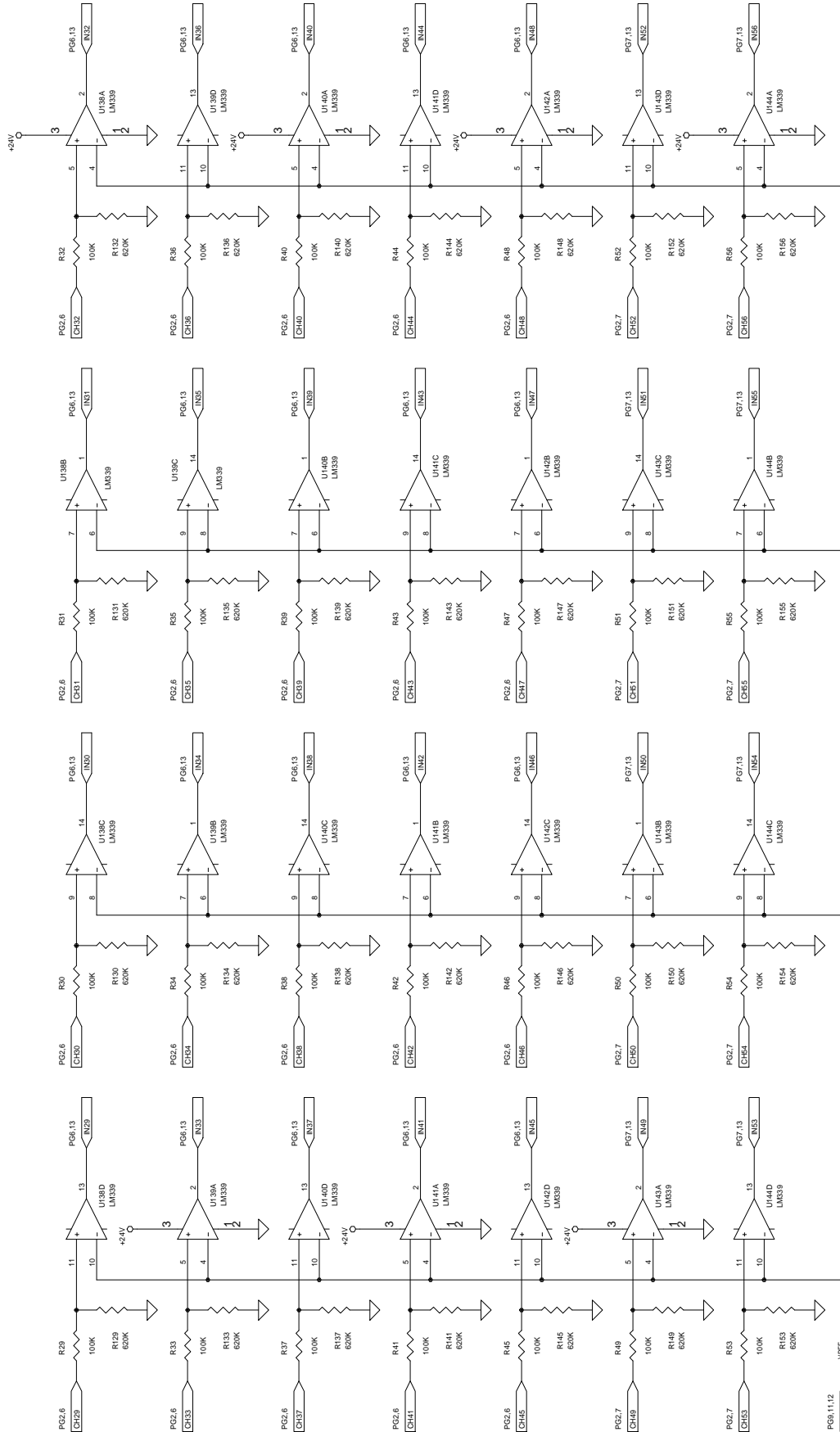

SIZE	BOOK IDENT. NO.	DOCUMENT NO.	REV.
B	21793	435069	A
SCALE	SHEET 10 OF 19		

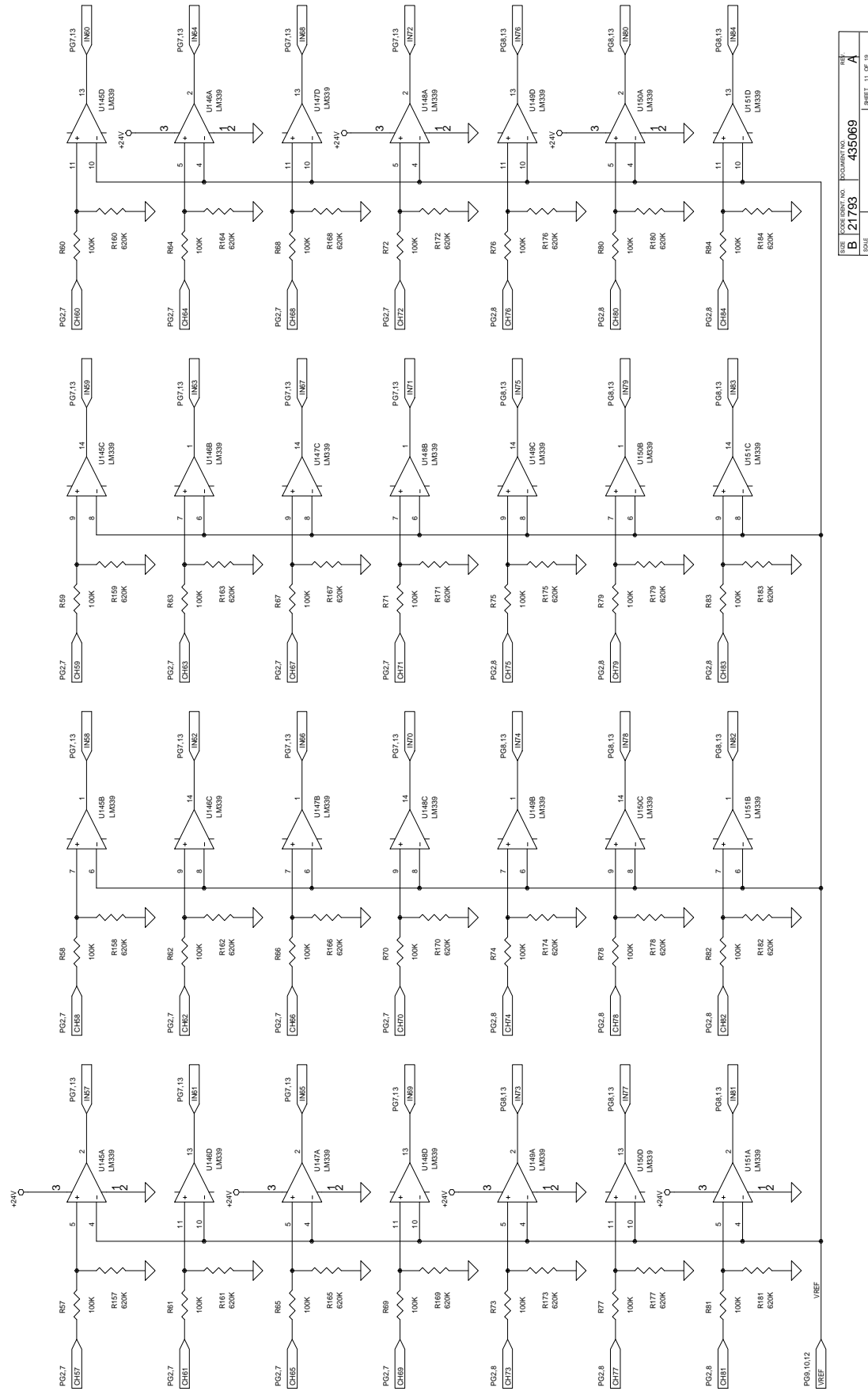

REV	DOC/REV NO	DOCUMENT NO	435069	SHEET	A
	B	21793			
SCALE					11 OF 19

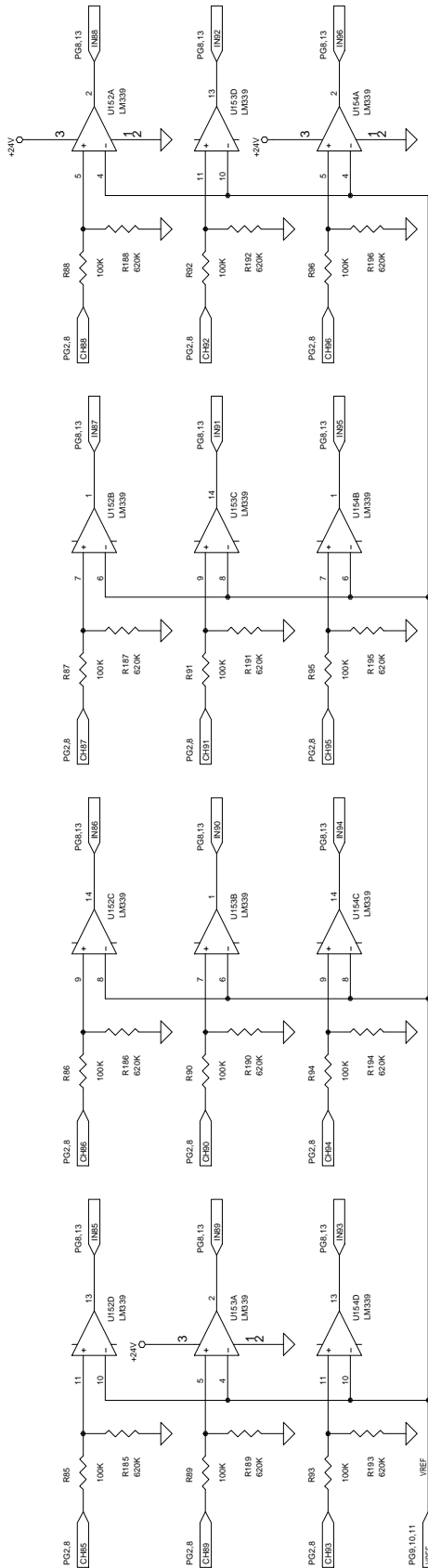

SIZE	FOR ORDERING AND DOCUMENTATION	REV.	A
B	Z1793	435069	
SCALE			SHEET 12 OF 19

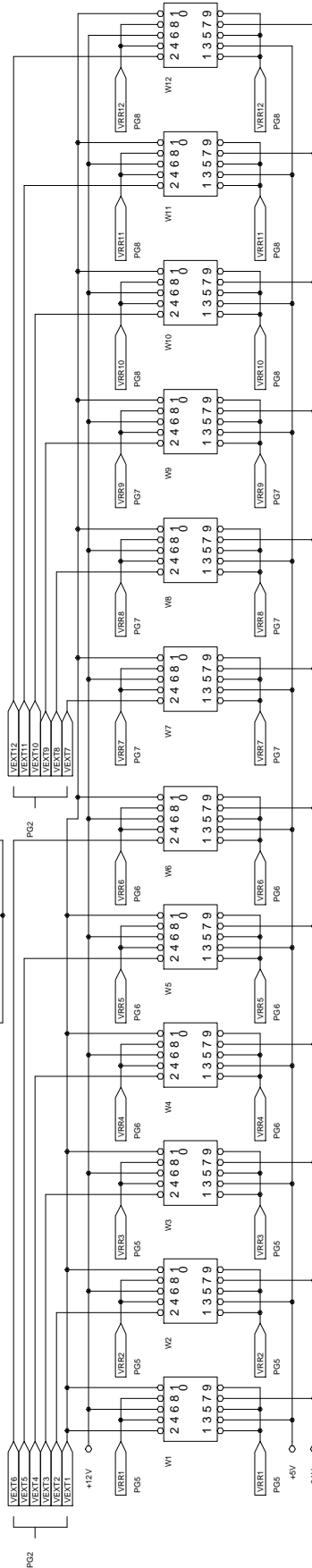
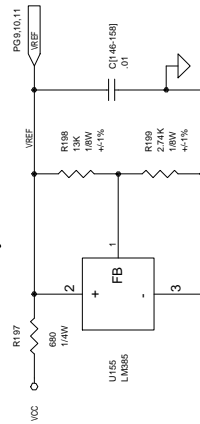

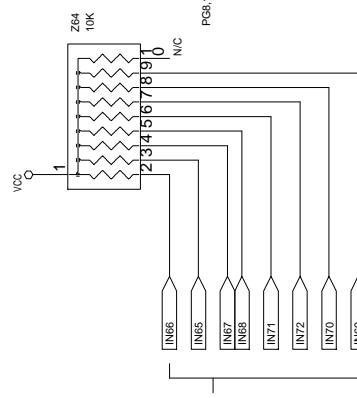
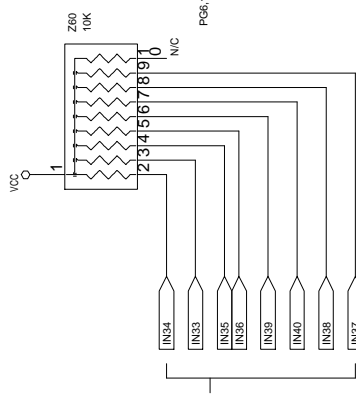
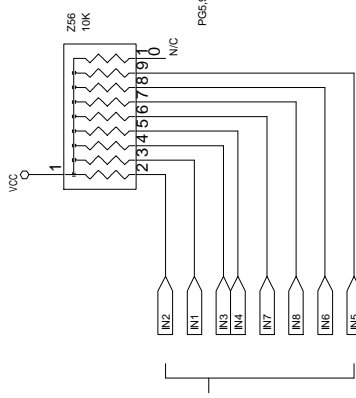
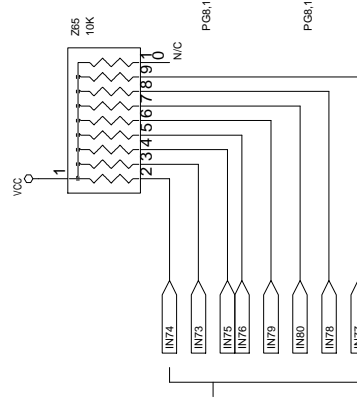
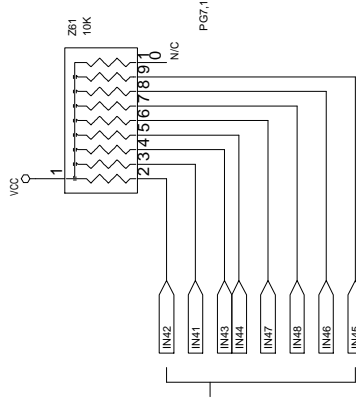
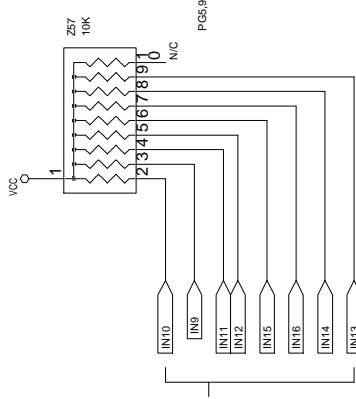
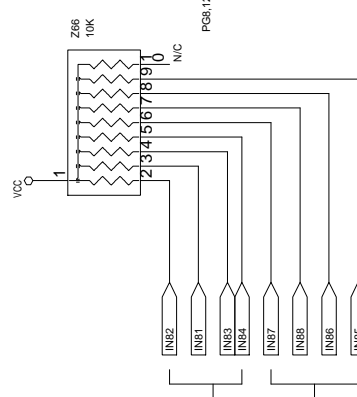
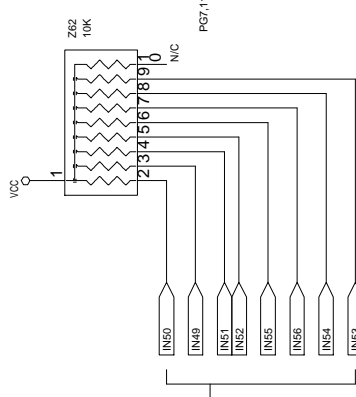
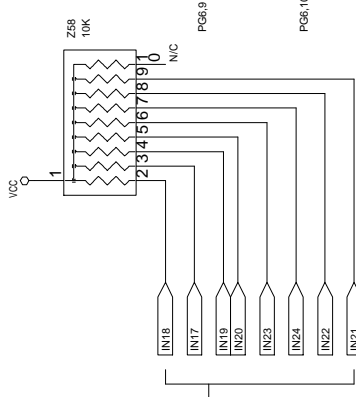
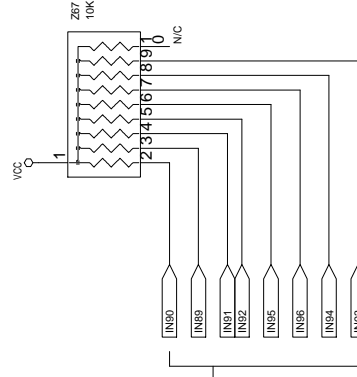
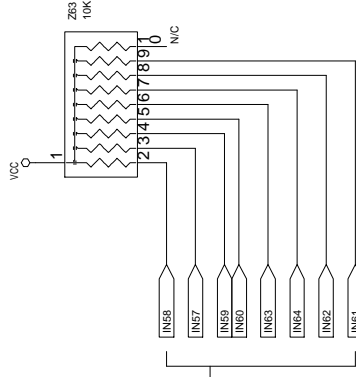
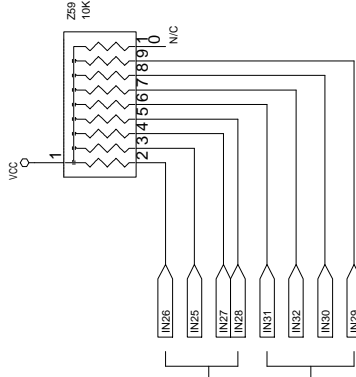

SIZE	FOR IDENT. NO.	DOCUMENT NO.	REV.
B	21793	435069	A
SCALE	SHEET 13 OF 39		

PG5,9

PG6,10

PG7,11

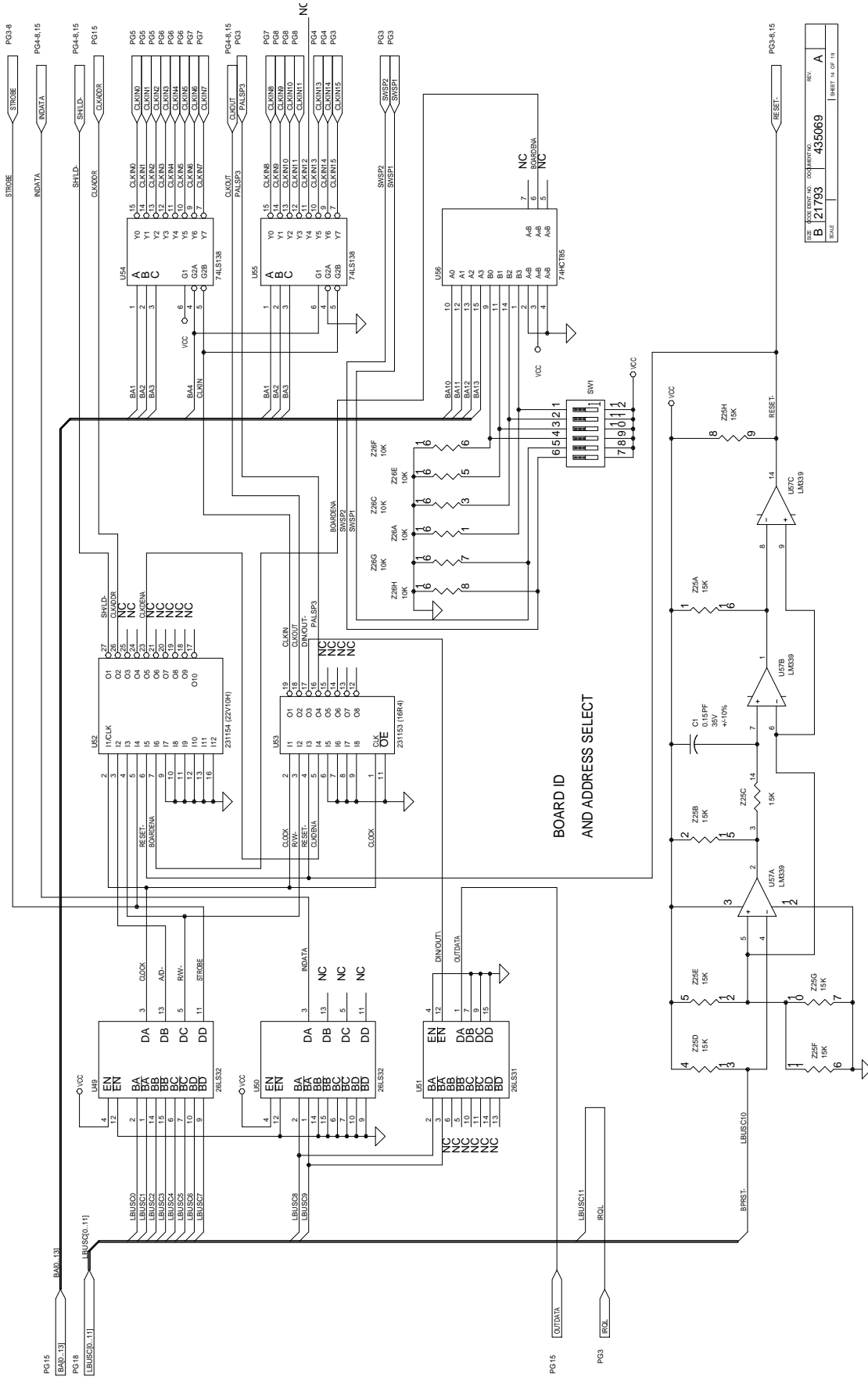

REV:	A
DOC NO:	435069
DATE:	
SHEET:	13 OF 13



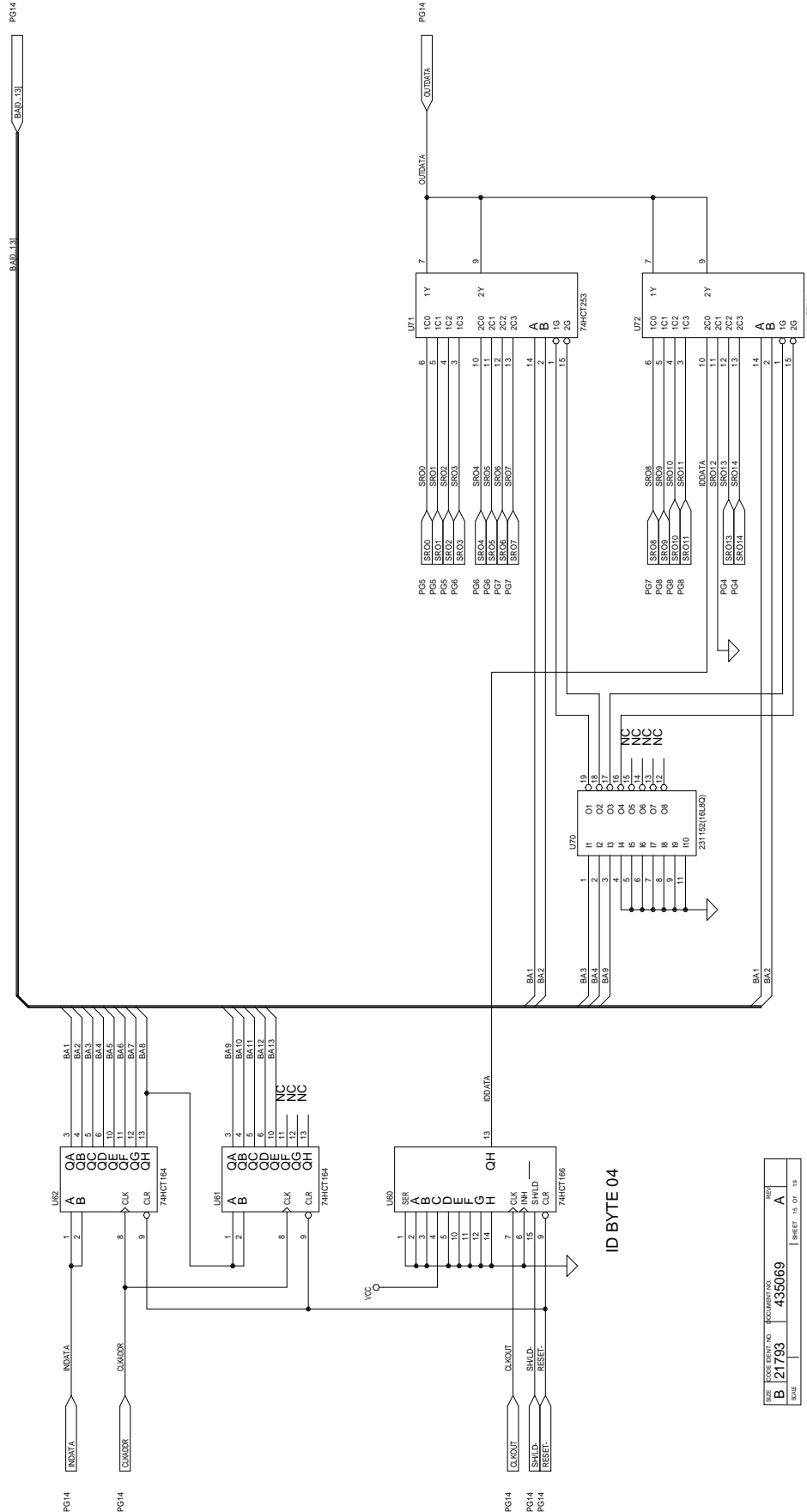

REV	DESCRIPTION	DATE
A	435069	
B	21793	

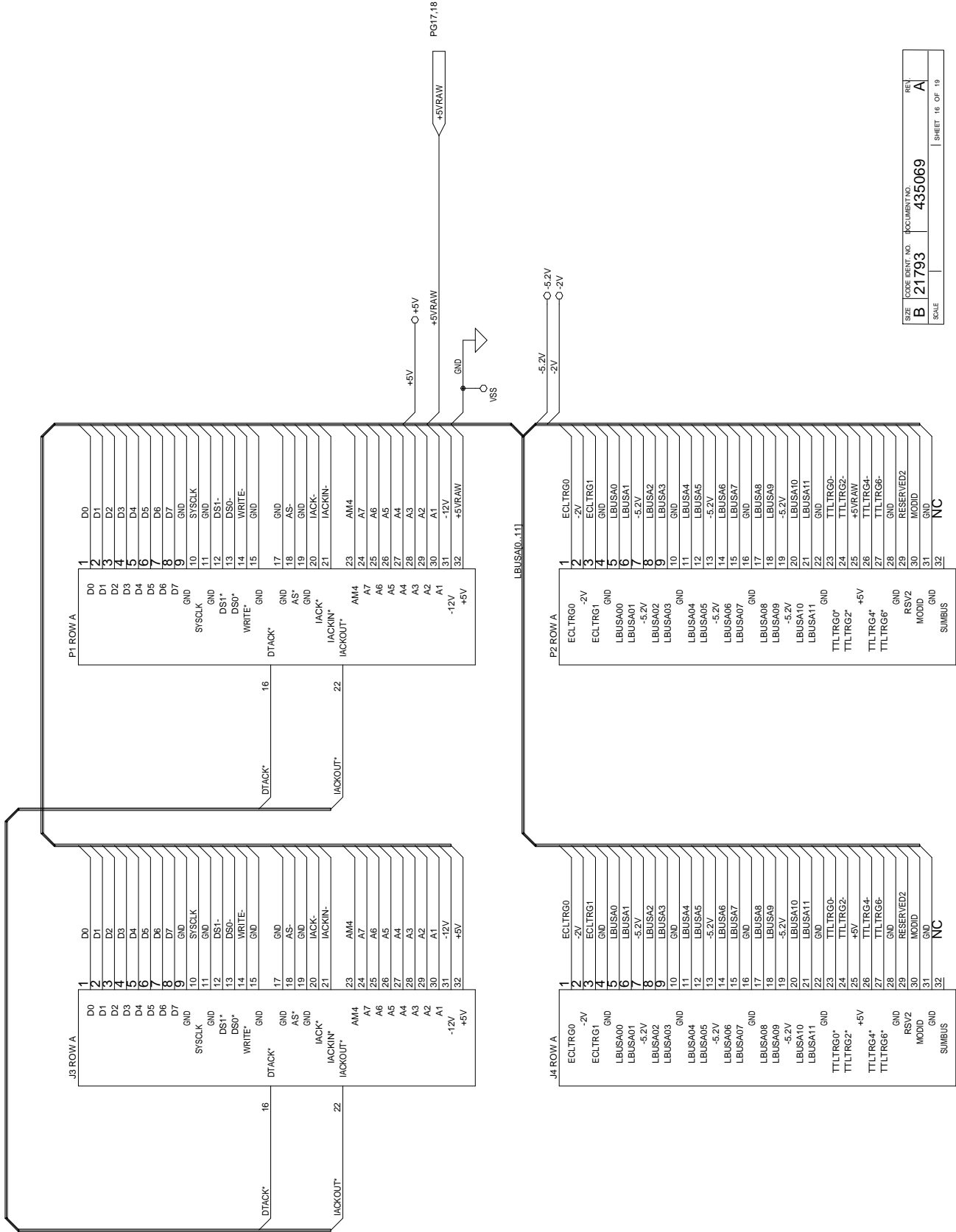

SIZE	CODE IDENT. NO.	DOCUMENT NO.	REV.
B	21793	435069	A
SCALE	SHEET 16 OF 19		

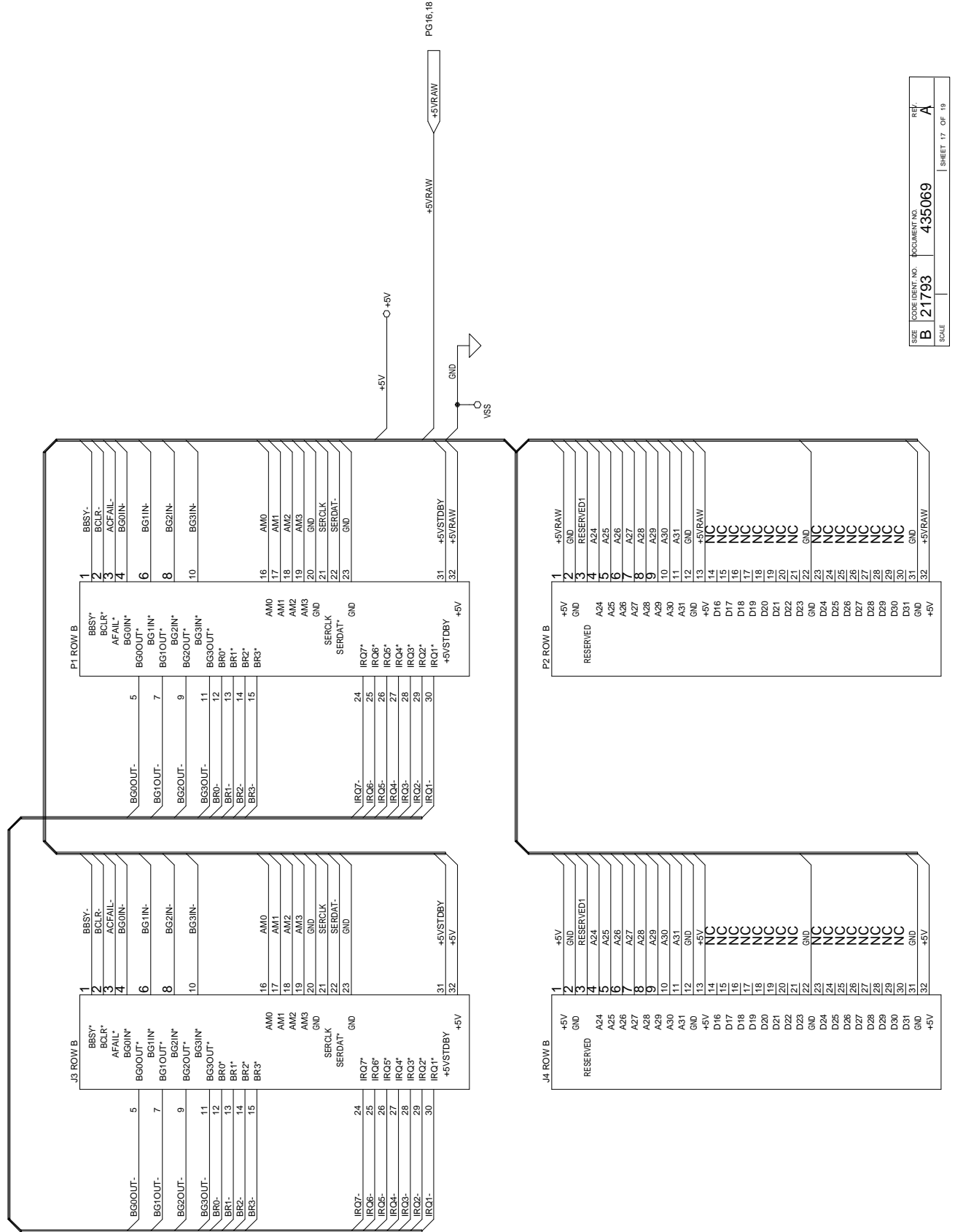

SIZE	CODE IDENT NO.	DOCUMENT NO.	REV.
B	21793	435069	A
SCALE			SHEET 17 OF 19



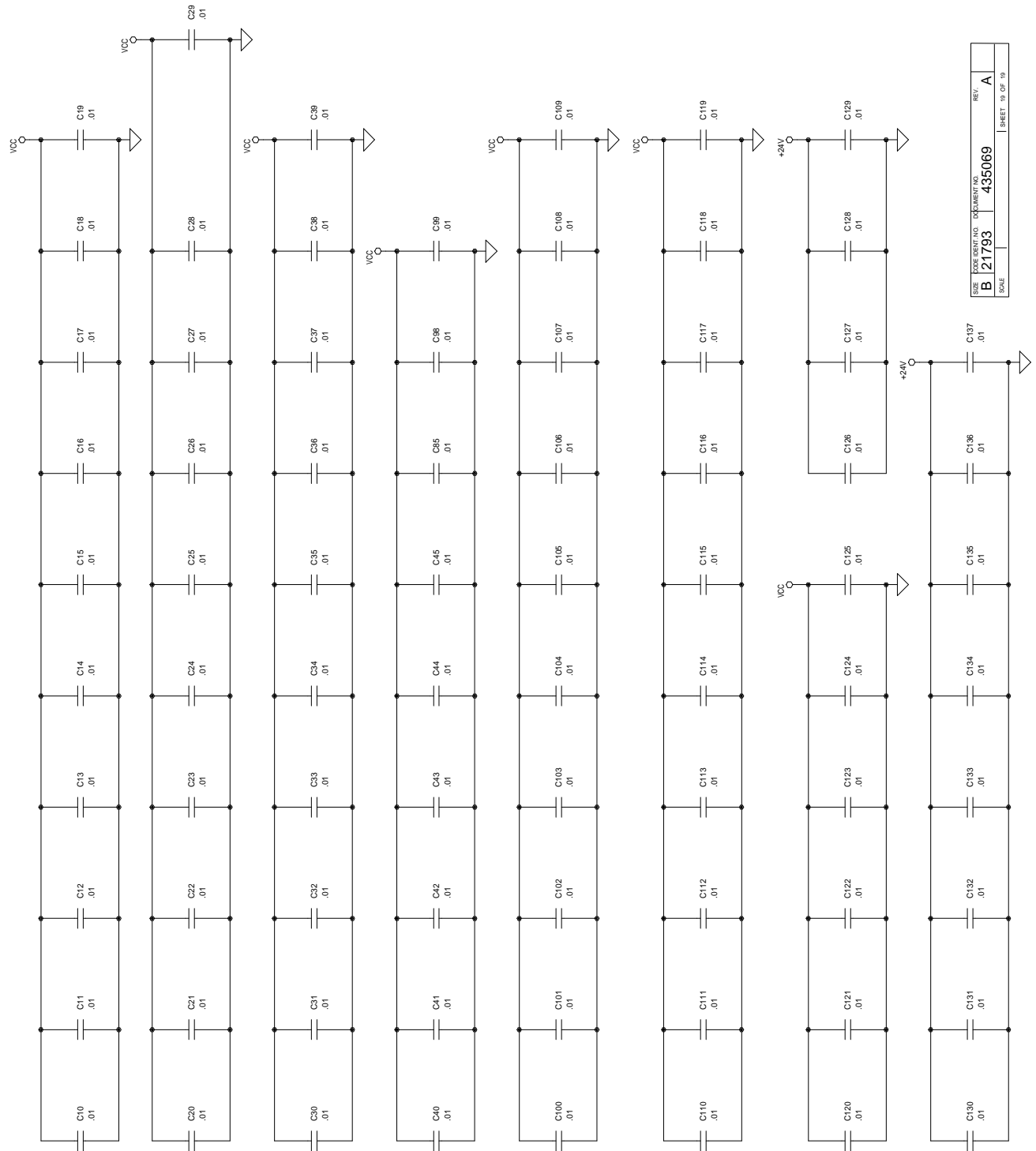

SIZE	LOAD SHEET NO.	DOCUMENT NO.	REV.	
B	21793	435069	A	
SCALE				SHEET 18 OF 19

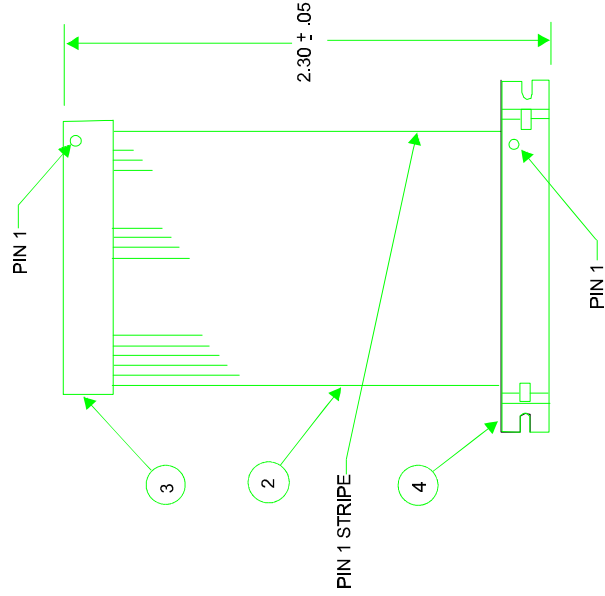

<b>RACAL Instruments, Inc.</b> 4 Goodyear St., Irvine, Ca 92718-2002	
TITLE <b>CABLE ASSY., 50 PIN</b>	
SIZE <b>A</b>	CODE IDENT. NO. <b>407179-002</b>
SCALE	REV. <b>B</b>
SHEET 1 OF 2	

**PROPRIETARY NOTICE**

THIS DOCUMENT AND THE TECHNICAL DATA HEREIN ARE THE PROPERTY OF RACAL INSTRUMENTS, INC. AND SHALL NOT BE REPRODUCED, COPIED, EITHER WHOLLY OR IN PART, OR USED TO SOLICIT QUOTES OR CONTRACTS FROM ANY OTHER MANUFACTURER WITHOUT THE WRITTEN PERMISSION OF RACAL INSTRUMENTS, INC. THE INFORMATION HEREON WAS OBTAINED FROM RACAL INSTRUMENTS, INC. AND IS NOT TO BE USED FOR ANY OTHER PURPOSES OF ENGINEERING, DESIGN, RESEARCH, OR DEVELOPMENT, WHICH SPECIFY PROCUREMENT OF PRODUCTS FROM RACAL INSTRUMENTS, INC.

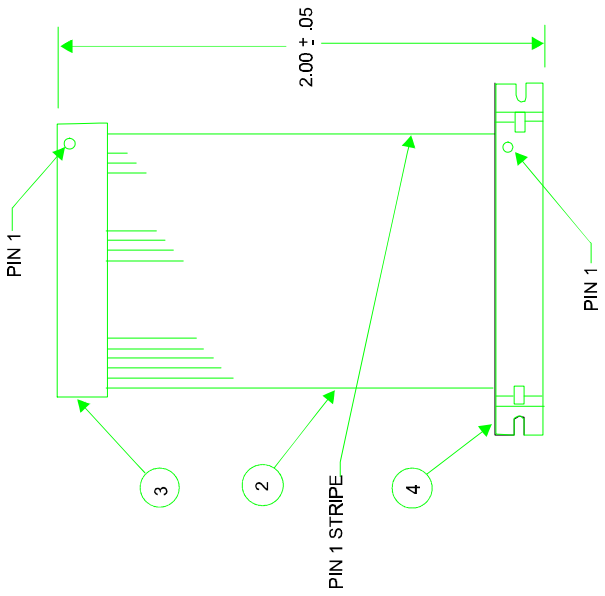

<b>RACAL Instruments, Inc.</b> 4 Goodyear St., Irvine, Ca 92718-2002	
TITLE <b>CABLE ASSY., 50 PIN</b>	
SIZE <b>A</b>	CODE IDENT. NO. <b>407179-001</b>
SCALE	REV. <b>B</b>
SHEET 1 OF 2	

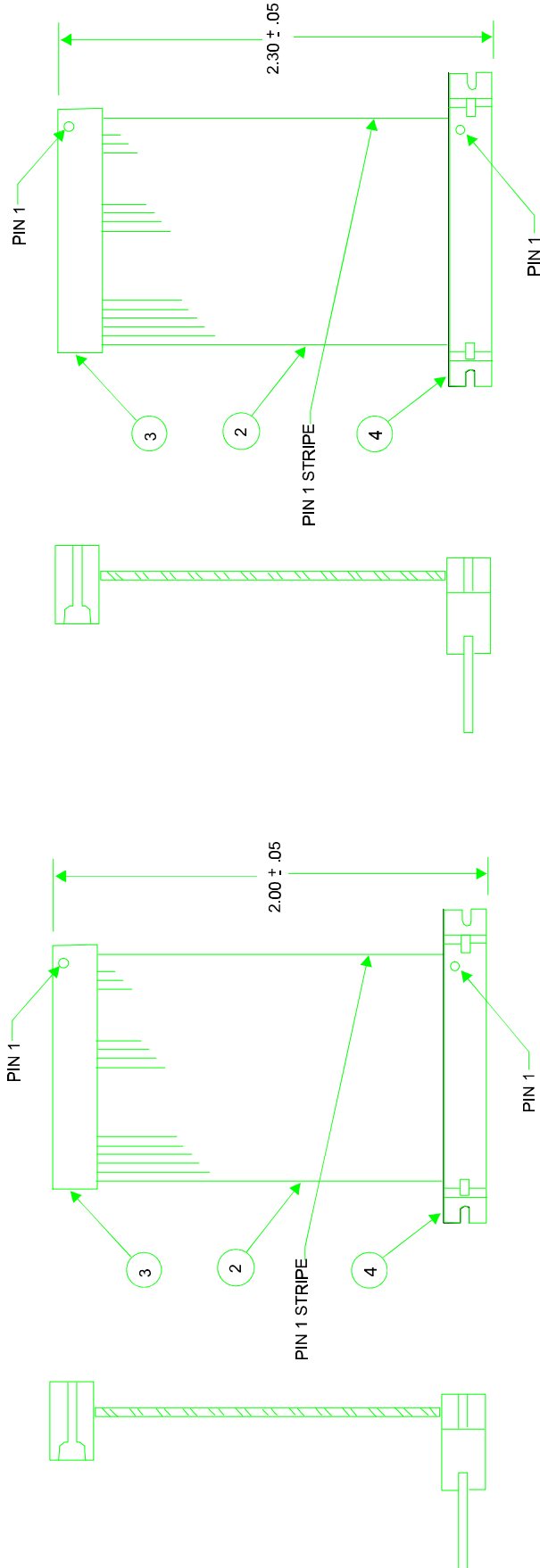

<b>RACAL Instruments, Inc.</b> 4 Goodyear St., Irvine, Ca 92718-2002	
TITLE <b>CABLE ASSY., 60 PIN</b>	
SIZE <b>A</b>	CODE IDENT. NO. <b>407180-002</b>
SCALE   SHEET 1 OF 2	

**PROPRIETARY NOTICE**

THIS DOCUMENT AND THE TECHNICAL DATA HEREIN ARE THE PROPERTY OF RACAL INSTRUMENTS, INC. AND SHALL NOT BE REPRODUCED, COPIED, EITHER WHOLE OR IN PART OR USED TO SOLICIT COPIES FROM ANY OTHER SOURCE WITHOUT THE EXPRESS WRITTEN PERMISSION OF RACAL INSTRUMENTS, INC. THE INFORMATION HEREON HAS BEEN DEVELOPED BY RACAL INSTRUMENTS, INC. FOR THE PURPOSES OF ENGINEERING EVALUATION AND FOR INCORPORATION INTO TECHNICAL DRAWINGS OF PRODUCTS FROM RACAL INSTRUMENTS, INC.

<b>RACAL Instruments, Inc.</b> 4 Goodyear St., Irvine, Ca 92718-2002	
TITLE <b>CABLE ASSY., 60 PIN</b>	
SIZE <b>A</b>	CODE IDENT. NO. <b>407180-001</b>
SCALE   SHEET 1 OF 2	

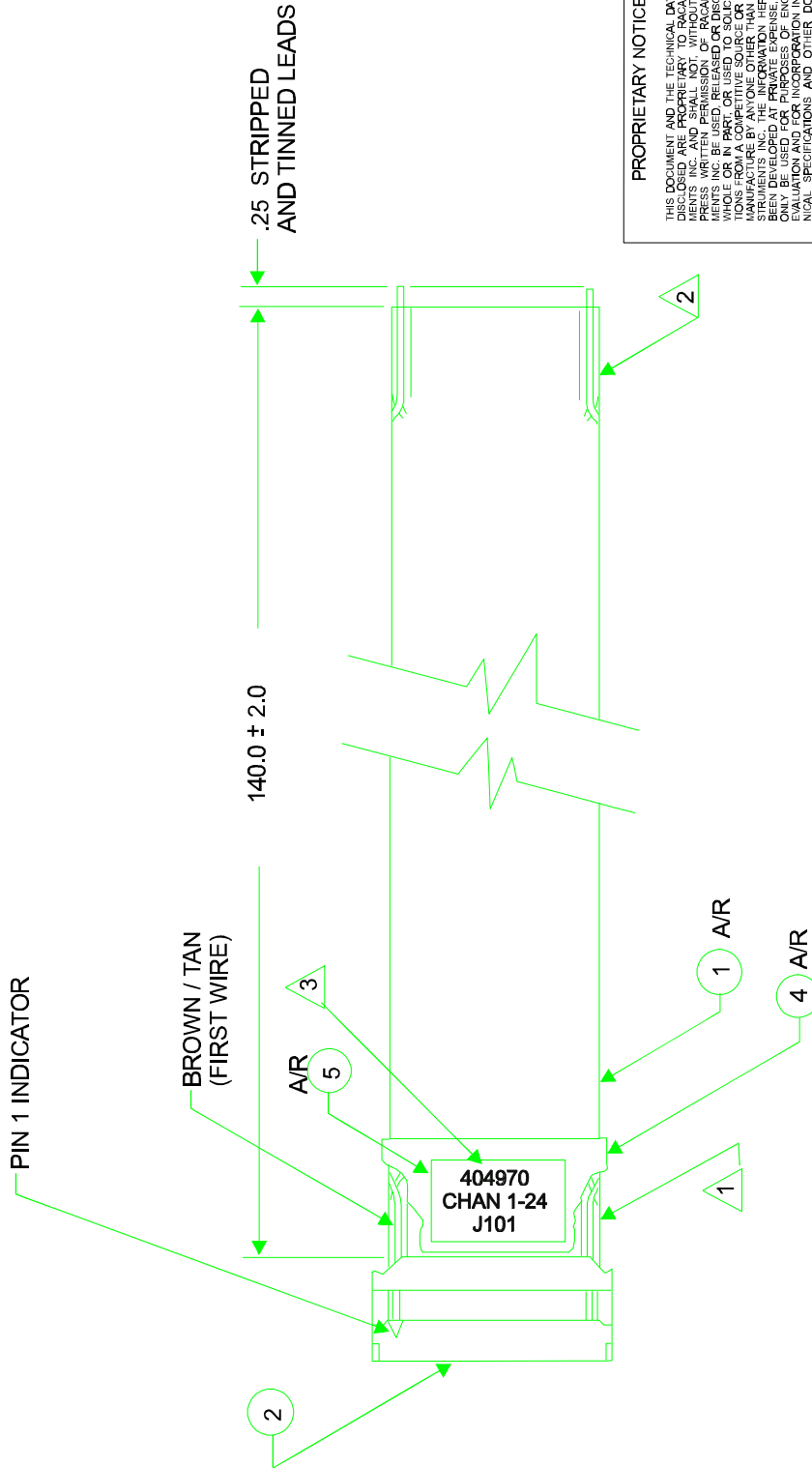

**PROPRIETARY NOTICE**

THIS DOCUMENT AND THE TECHNICAL DATA HEREIN DISCLOSED ARE PROPRIETARY TO RACAL INSTRUMENTS INC. AND PERMISSION OF RACAL INSTRUMENTS INC. BE USED, REPRODUCED, COPIED, OR TRANSMITTED IN ANY FORM OR BY ANY MEANS, ELECTRONIC OR MECHANICAL, INCLUDING PHOTOCOPYING, RECORDING, OR BY ANY INFORMATION STORAGE AND RETRIEVAL SYSTEM, WITHOUT THE WRITTEN PERMISSION OF RACAL INSTRUMENTS INC. THIS INFORMATION IS THE PROPERTY OF RACAL INSTRUMENTS INC. AND IS NOT TO BE DISCLOSED TO ANY OTHER MANUFACTURER BY ANYONE OTHER THAN RACAL INSTRUMENTS INC. THE INFORMATION HEREON HAS BEEN DEVELOPED AT PRIVATE EXPENSE, AND MAY BE USED FOR RESEARCH AND DEVELOPMENT, TESTING, EVALUATION AND FOR INCORPORATION INTO TECHNICAL SPECIFICATIONS AND OTHER DOCUMENTS WHICH SPECIFY PROCUREMENT OF PRODUCTS FROM RACAL INSTRUMENTS INC.

**RACAL Instruments, Inc.**  
4 Goodyear St., Irvine, Ca 92718-2002

**TITLE**  
**CABLE ASSY, J101**  
1260-14,

SIZE	CODE IDENT. NO.	DOCUMENT NO.	REV.
C	21793	404970	A
SCALE			SHEET 1 OF 2

- 3. MARK CABLE USING BLACK EPOXY INK OR EQUIVALENT
- 2. LEADS TO BE STRIPPED AND TINNED IN STRAIGHT (NON-TWISTED) SECTION OF CABLE.
- 1. CONNECTOR (ITEM 2) TO BE INSTALLED IN STRAIGHT (NON-TWISTED) SECTION OF CABLE.

NOTES: UNLESS OTHERWISE SPECIFIED



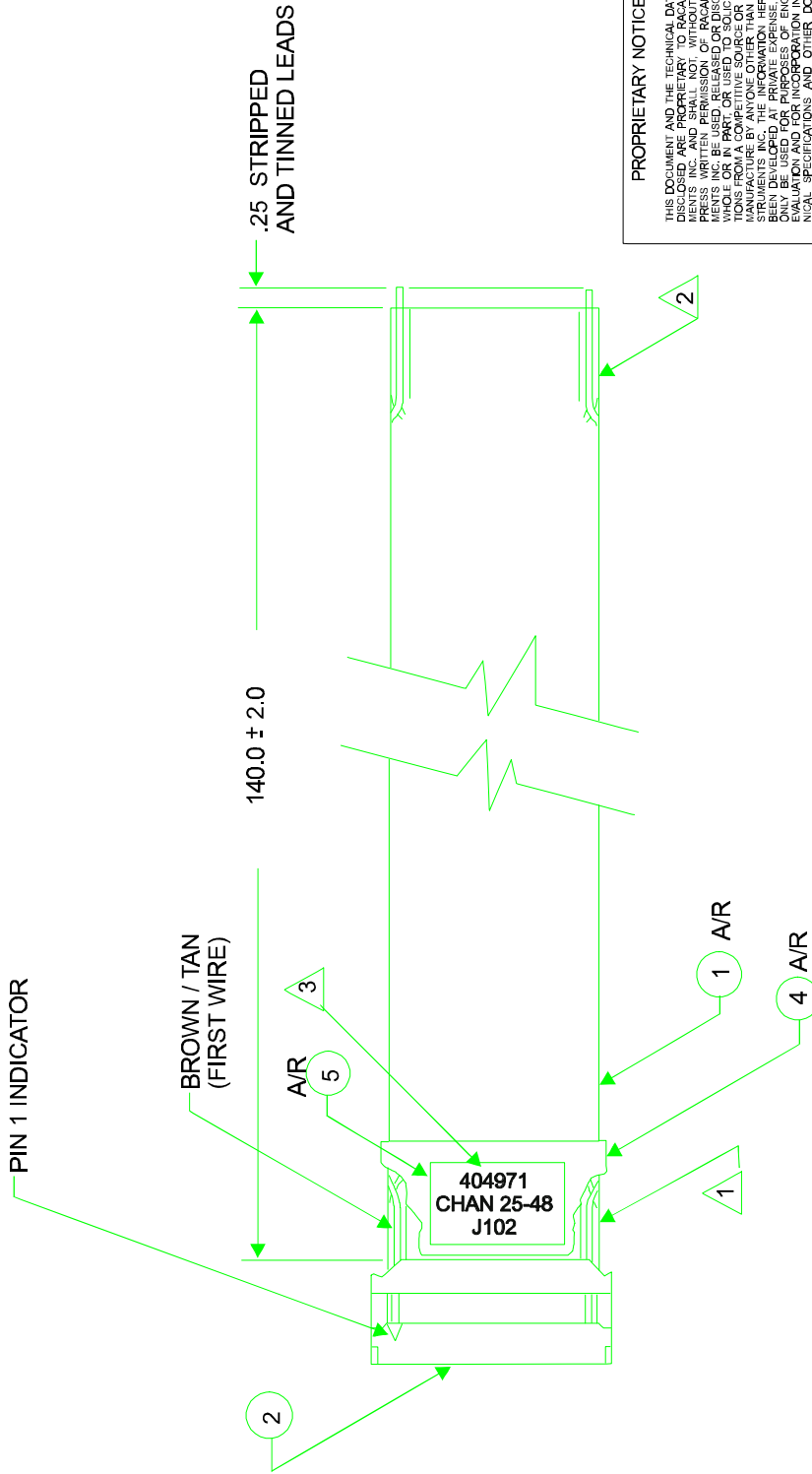

**PROPRIETARY NOTICE**  
 THIS DOCUMENT AND THE TECHNICAL DATA HEREIN ARE THE PROPERTY OF RACAL INSTRUMENTS, INC. AND SHALL NOT BE REPRODUCED, COPIED, OR TRANSMITTED IN ANY FORM OR BY ANY MEANS, WITHOUT THE EXPRESS WRITTEN PERMISSION OF RACAL INSTRUMENTS, INC. THIS NOTICE SHALL BE REPRODUCED AND DISPLAYED ON ALL COPIES OF THIS DOCUMENT. NO PART OF THIS DOCUMENT IS TO BE REPRODUCED OR TRANSMITTED IN ANY FORM OR BY ANY MEANS, WITHOUT THE EXPRESS WRITTEN PERMISSION OF RACAL INSTRUMENTS, INC. THIS DOCUMENT IS THE PROPERTY OF RACAL INSTRUMENTS, INC. AND IS LOANED TO YOU FOR YOUR USE ONLY. IT IS NOT TO BE REPRODUCED, COPIED, OR TRANSMITTED IN ANY FORM OR BY ANY MEANS, WITHOUT THE EXPRESS WRITTEN PERMISSION OF RACAL INSTRUMENTS, INC. THIS DOCUMENT IS THE PROPERTY OF RACAL INSTRUMENTS, INC. AND IS LOANED TO YOU FOR YOUR USE ONLY. IT IS NOT TO BE REPRODUCED, COPIED, OR TRANSMITTED IN ANY FORM OR BY ANY MEANS, WITHOUT THE EXPRESS WRITTEN PERMISSION OF RACAL INSTRUMENTS, INC.

- 3. MARK CABLE USING BLACK EPOXY INK OR EQUIVALENT
- 2. LEADS TO BE STRIPPED AND TINNED IN STRAIGHT (NON-TWISTED) SECTION OF CABLE.
- 1. CONNECTOR (ITEM 2) TO BE INSTALLED IN STRAIGHT (NON-TWISTED) SECTION OF CABLE.

NOTES: UNLESS OTHERWISE SPECIFIED

<b>RACAL Instruments, Inc.</b> 4 Goodyear St., Irvine, Ca 92718-2002	
TITLE <b>CABLE ASSY, J102</b>	
SIZE <b>C</b>	CODE IDENT. NO. <b>21793</b>
SCALE	DOCUMENT NO. <b>404971</b>
	REV. <b>A</b>
SHEET 1 OF 2	

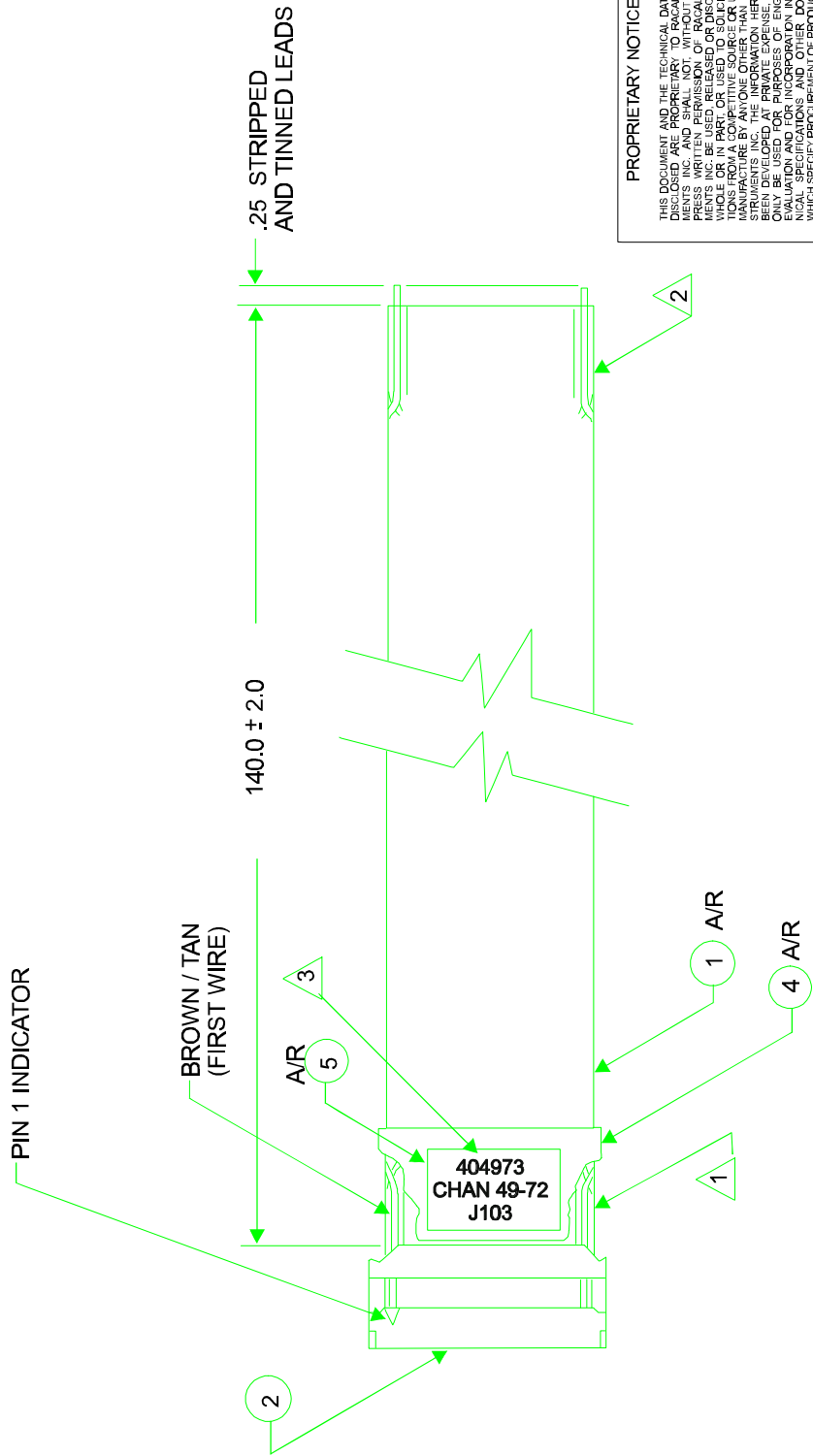

**PROPRIETARY NOTICE**

THIS DOCUMENT AND THE TECHNICAL DATA HEREIN DISCLOSED ARE PROPRIETARY TO RACAL INSTRUMENTS INC. AND SHALL NOT, WITHOUT THE EXPRESS WRITTEN PERMISSION OF RACAL INSTRUMENTS INC., BE REPRODUCED, COPIED, TRANSMITTED, OR IN ANY MANNER USED TO PROMOTE OR INFRINGE ON THE PATENT RIGHTS OR INTELLECTUAL PROPERTY OF RACAL INSTRUMENTS INC. OR ANY OTHER MANUFACTURER BY ANYONE OTHER THAN RACAL INSTRUMENTS INC. THIS NOTICE IS APPLICABLE TO ALL INFORMATION AND FOR INFORMATION INTO TECHNICAL DRAWINGS AND SPECIFICATIONS WHICH SPECIFY PROCUREMENT OF PRODUCTS FROM RACAL INSTRUMENTS INC.

- 3. MARK CABLE USING BLACK EPOXY INK OR EQUIVALENT
- 2. LEADS TO BE STRIPPED AND TINNED IN STRAIGHT (NON-TWISTED) SECTION OF CABLE.
- 1. CONNECTOR (ITEM 2) TO BE INSTALLED IN STRAIGHT (NON-TWISTED) SECTION OF CABLE.

NOTES: UNLESS OTHERWISE SPECIFIED

<b>RACAL Instruments, Inc.</b>	
4 Goodyear St., Irvine, Ca 92718-2002	
TITLE	
<b>CABLE ASSY, J103</b>	
SIZE	DOCUMENT NO.
<b>C 21793</b>	<b>404973</b>
SCALE	REV.
	<b>A</b>
SHEET 1 OF 2	

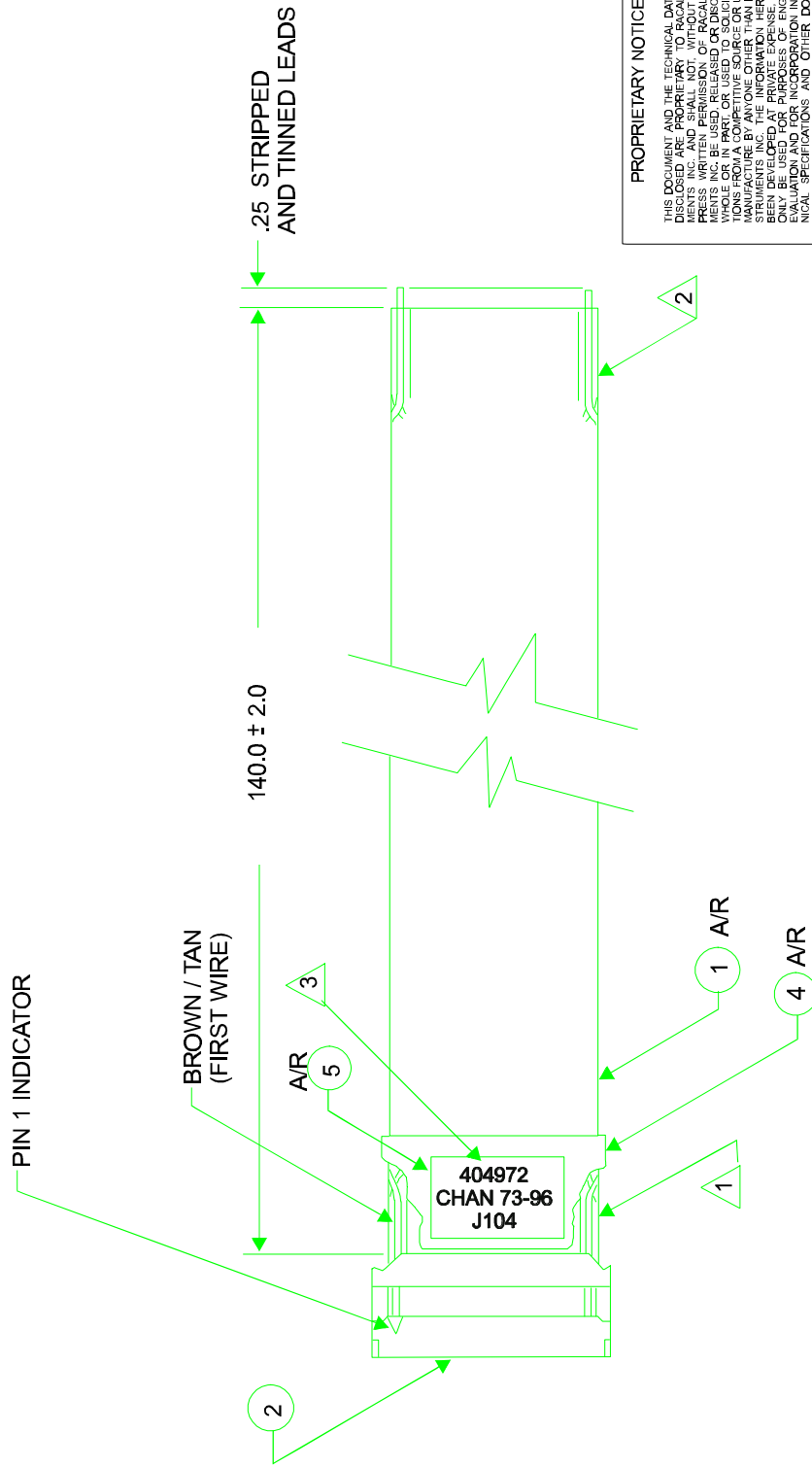

**PROPRIETARY NOTICE**  
 THIS DOCUMENT AND THE TECHNICAL DATA HEREIN DISCLOSED ARE PROPRIETARY TO RACAL INSTRUMENTS, INC. AND SHALL NOT, WITHOUT THE EXPRESS WRITTEN PERMISSION OF RACAL INSTRUMENTS, INC., BE REPRODUCED, COPIED, OR TRANSMITTED IN ANY FORM OR BY ANY MEANS, ELECTRONIC OR MECHANICAL, INCLUDING PHOTOCOPYING, RECORDING, OR BY ANY INFORMATION STORAGE AND RETRIEVAL SYSTEM. THIS DOCUMENT IS THE PROPERTY OF RACAL INSTRUMENTS, INC. AND IS LOANED TO YOU. IT IS TO BE USED ONLY FOR THE PROJECT AND FOR THE QUANTITY SPECIFIED IN THE ORDER. IT IS NOT TO BE USED FOR ANY OTHER PROJECT OR FOR ANY OTHER QUANTITY. RACAL INSTRUMENTS, INC. IS NOT RESPONSIBLE FOR ANY DAMAGE TO OR LOSS OF DATA FROM ANY DEVICE OR SYSTEM WHICH MAY BE USED IN CONNECTION WITH THIS DOCUMENT. RACAL INSTRUMENTS, INC. IS NOT RESPONSIBLE FOR ANY DAMAGE TO OR LOSS OF DATA FROM ANY DEVICE OR SYSTEM WHICH MAY BE USED IN CONNECTION WITH THIS DOCUMENT. RACAL INSTRUMENTS, INC. IS NOT RESPONSIBLE FOR ANY DAMAGE TO OR LOSS OF DATA FROM ANY DEVICE OR SYSTEM WHICH MAY BE USED IN CONNECTION WITH THIS DOCUMENT. RACAL INSTRUMENTS, INC. IS NOT RESPONSIBLE FOR ANY DAMAGE TO OR LOSS OF DATA FROM ANY DEVICE OR SYSTEM WHICH MAY BE USED IN CONNECTION WITH THIS DOCUMENT.

<b>RACAL Instruments, Inc.</b>		4 Goodyear St., Irvine, Ca. 92718-2002	
TITLE			
<b>CABLE ASSY, J104</b>		1260-14, J104	
SIZE	CODE IDENT. NO.	DOCUMENT NO.	REV.
C	21793	404972	A
SCALE			SHEET 1 OF 2

- 3. MARK CABLE USING BLACK EPOXY INK OR EQUIVALENT
- 2. LEADS TO BE STRIPPED AND TINNED IN STRAIGHT (NON-TWISTED) SECTION OF CABLE.
- 1. CONNECTOR (ITEM 2) TO BE INSTALLED IN STRAIGHT (NON-TWISTED) SECTION OF CABLE.

NOTES: UNLESS OTHERWISE SPECIFIED

This page was intentionally left blank

## Chapter 5

# PARTS LIST

---

407164	Final Assy., 1260-14C.....	5-3
405069	PCB Assy., 1260-14C.....	5-4
407179-001	PCB Cable Assy., 50-pin.....	5-7
407179-002	PCB Cable Assy., 50-pin.....	5-7
407180-001	PCB Cable Assy., 60-pin.....	5-7
407180-002	PCB Cable Assy., 60-pin.....	5-7
404936-001	Shipping Kit, 1260-14C.....	5-8
404974	External Cable Assy. Kit, 1260-14C.....	5-8
404970	Cable Assy., J101.....	5-9
404971	Cable Assy., J102.....	5-9
404973	Cable Assy., J103.....	5-9
404972	Cable Assy., J104.....	5-9
	List of Suppliers.....	5-10

This page was left intentionally blank.

## User Manual 1260-14C

---

407164 FINAL ASSY., KIT , 1260-14C

REF DESIG	RACAL INST P/N	DESCRIPTION	FSC	MANUFACTURER'S P/N
(1)1	405069	PCB ASSY., 1260-14C	21793	4050690
(3)1	404936-001	SHIPPING KIT, 1260-14C	21793	404936-001
(5)1	455901	PANEL, RIGHT SIDE	21793	455901
(6)1	455779-003	PANEL, SIDE, LEFT	21793	455779-003
(9)1	455781	PANEL, REAR, SINGLE	21793	455781
(10)1	455784-001	PANEL, VXI TOP	21793	455784-001
(11)1	455784-002	PANEL, VXI BGTOM	21793	455784-002
{14}32	615539	SCREW, PFH, 4-40X. 125		
(16)8	616480	SCREW, PFH, 4-40 X .375		
(17)1	920710	LABEL, IDENIFICATION	21793	920710
(18)1	921212-027	LABEL, VXI, 1260-14C	21793	921212-02740
(19)A/R	920962	LOCTITE. 242, MED STR.	05972	272
(21)1	921059	LABEL, CAUTION, STATIC	21793	921059
(23)1	921309	LABEL, VXI SWITCH ID	21793	921309

405069 PCB ASSY., 1260-14C

REF DESIG	RACAL INST P/N	DESCRIPTION	FSC	MANUFACTURER'S P/N
C1	110165	CAP, TANTA, .15 MF, 35V, 10PCT	05397	T355A154K035A5
C2	110126	CAP, TANTA, 6. 8UF, 35V, 20 PERCENT	05397	T355F685M035A5
C3	110126	CAP, TANTA, 6. 8UF, 35V, 20 PERCENT	05397	T355F685M035A5
C10-C45	R-21-1801	CAP, CHIP, 10 NF	95275	VJ1206Y103MF
C82	R-21-1801	CAP, CHIP, 10 NF	95275	VJ1206Y103MF
C83	R-21-1801	CAP, CHIP, 10 NF	95275	VJ1206Y103MF
C85	R-21-1801	CAP, CHIP, 10 NF	95275	VJ1206Y103MF
C98-C138	R-21-1801	CAP, CHIP, 10 NF	95275	VJ1206Y103MF
C139	110126	CAP, TANTA, 6. 8UF, 35V, 20 PERCENT	05397	T355F685M035A5
C140	110126	CAP, TANTA, 6. 8UF, 35V, 20 PERCENT	05397	T355F685M035A5
C141	R-21-1801	CAP, CHIP, 10 NF	95275	VJ1206Y103MF
C142	R-21-1801	CAP, CHIP, 10 NF	95275	VJ1206Y103MF
C143	110126	CAP, TANTA, 6. RUF, 35V, 20 PERCENT	05397	T355F685M035A5
C144	110126	CAP, TANTA, 6. RUF, 35V, 20 PERCENT	05397	T355F685M035A5
C145-C158	R-21-1801	CAP, CHIP, 10 NF	95275	VJ1206Y103MF
J3	601925	CONNECTOR, PCB, RECEPT, 3 ROW, 96P	52072	618008
J4	601925	CONNECTOR, PCB, RECEPT, 3 ROW, 96P	52072	618008
L1	310193	CHOKER, SHIELDED, SUH	91637	IH-5-5-10
L6	100164	CAP, FEED-THRU,800PF, 50v	00779	842448-2
L7	100164	CAP, FEED-THRU,800PF, 50v	00779	842448-2
L8	310193	CHOKER, SHIELDED, SUH	91637	IH-5-5-10
L9	100164	CAP, FEED-THRU,800PF, 50v	00779	842448-2
L10	310193	CHOKER, SHIELDED, SUH	91637	IH-5-5-10
P1	601675-001	CONNECTOR, EUROCARD, 96 PIN MOD.	21793	601675-001
P2	601675-001	CONNECTOR, EUROCARD, 96 PIN MOD.	21793	601675-001
P101	601604	CONNECTOR, PCB, PLUG, 50-PIN, STRAIGHT	08261	842-800-571-000
P102	601604	CONNECTOR, PCB, PLUG, 50-PIN, STRAIGHT	08261	842-800-571-000
P103	601169	CONNECTOR, IDC, 60P, BREAKAWAY	55322	TSW-130-07-G-D
P104	601169	CONNECTOR, IDC, 60P, BREAKAWAY	55322	TSW-130-07-G-D
R1-R96	050000-104	RES, CHIP, LOOK, .06W, SPCT	91637	O80SERIES
R101-R196	050000-624	RES, CHIP, 620K, .06W, SPCT	91637	O80SERIES
R197	000681	RES,CARBON, 680 OHM,1/4W,5 PERCENT	81349	RCO7GF681J
R198	010523	RES, METAL, 13K, 1/8W, 1PCT	81349	RN60D1302F
R199	010778	RES, METAL, 2.74K, 1/8W, 1PCT 100K, .06W, 5PCT	81349	RN55C2741F
R200	050000-104	RES, CHIP, 6 POS, LOW PROFILE	91637	O80SERIES
SW1-5W3	601969	SWITCH, DIP .025SQ	65832	K4065
TP1	601197	POST, TEST, .025SQ SHIFT REGISTER FLIP FLOP	00779	6-87022-6
TP2	601197	POST, TEST, 8-BIT, PARALLEL/SERIAL OUT S.R.	00779	6-87022-6
U1	231131	IC, DIGITAL, DIGITAL, SHIFT REGISTER	18324	PC74HCT164D
U2	231130	IC, DIGITAL, DIGITAL, FLIP FLOP	18324	PC74HC273
U4	231120	IC, 8-BIT, PARALLEL/SERIAL OUT S.R	18324	74HCT166D
U5	231131	IC, DIGITAL, SHIFT REGISTER	18324	PC74HCT164D
U6	231130	IC, DIGITAL, FLIP FLOP	18324	PC74HC273
UB	231120	IC, 8-BIT, PARALLEL/SERIAL OUT S.R	18324	74HCT166D
U9	231131	IC, DIGITAL, SHIFT REGISTER	18324	PC74HCT164D
U10	231130	IC, DIGITAL, FLIP FLOP	18324	PC74HC273
U12	231120	IC, 8-BIT, PARALLEL/SERIAL OUT S.R.	18324	74HCT166D
U13	231131	IC, DIGITAL, SHIFT REGISTER	18324	PC74HCT164D
U14	231130	IC, DIGITAL, FLIP FLOP	18324	PC74HC273
U16	231120	IC, 8-BIT, PARALLEL/SERIAL OUT S.R.	18324	74HCT166D
U17	231131	IC, DIGITAL, SHIFT REGISTER	18324	PC74HCT164D
U18	231130	IC, DIGITAL, FLIP FLOP	18324	PC74HC273
U20	231120	IC, 8-BIT, PARALLEL/SERIAL OUT S.R.	18324	74HCT166D
U21	231131	IC, DIGITAL, SHIFT REGISTER	18324	PC74HCT164D
U22	231130	IC, DIGITAL, FLIP FLOP	18324	PC74HC273
U24	231120	IC, 8-BIT, PARALLEL/SERIAL OUT S.R.	18324	74HCT166D
U25	231131	IC, DIGITAL, SHIFT REGISTER	18324	PC74HCT164D
U26	231130	IC, DIGITAL, FLIP FLOP	18324	PC74HC273
U28	231120	IC, 8-BIT, PARALLEL/SERIAL OUT S.R.	18324	74HCT166D
U29	231131	IC, DIGITAL, SHIFT REGISTER	18324	PC74HCT164D



## User Manual 1260-14C

405069 PCB ASSY., 1260-14C

REF DESIG	RACAL INST P/N	DESCRIPTION	FSC	MANUFACTURER'S P/N
U30	231130	IC, DIGITAL, FLIP FLOP	18324	PC74HC273
U32	231120	IC, 8-BIT, PARALLEL/SERIAL OUT S.R.	18324	74HCT166D
U33	231131	IC, DIGITAL, SHIFT REGISTER	18324	PC74HCT164D
U34	231130	IC, DIGITAL, FLIP FLOP	18324	PC74HC273
U36	231120	IC, 8-BIT, PARALLEL/SERIAL OUT S.R.	18324	74HCT166D
U37	231131	IC, DIGITAL, SHIFT REGISTER	18324	PC74HCT164D
U38	231130	IC, DIGITAL, FLIP FLOP	18324	PC74HC273
U40	231120	IC, 8-BIT, PARALLEL/SERIAL OUT S.R.	18324	74HCT166D
U41	231131	IC, DIGITAL, SHIFT REGISTER	18324	PC74HCT164D
U42	231130	IC, DIGITAL, FLIP FLOP	18324	PC74HC273
U44	231120	IC, 8-BIT, PARALLEL/SERIAL OUT S.R.	18324	74HCT166D
U45	231131	IC, DIGITAL, SHIFT REGISTER	18324	PC74HCT164D
U46	231130	IC, DIGITAL, FLIP FLOP	18324	PC74HC273
U48	231120	IC, 8-BIT, PARALLEL/SERIAL OUT S.R.	18324	74HCT166D
U49	231096	IC, QUAD DIFF RECEIVER	01295	AM26LS32ACD
U50	231096	IC, QUAD DIFF RECEIVER	01295	AM26LS32ACD
U51	231125	IC, DIGITAL, LINE DRIVER	27014	D526L531MN
U52	231154	IC, PROGRAMMED PLA	21793	231154
U53	231153	IC, PROGRAMMED PLA	21793	231153
U54	231094	IC, DEMUX DECODER	18324	N74L5138D
U55	231094	IC, DEMUX DECODER	18324	N74L5138D
U56	231135	IC, DIGITAL, 4-BIT COMPARATOR	18324	PC74HCT85D
U57	231093	IC, QUAD COMPARATOR	04713	LM339D
U60	231120	IC, 8-BIT, PARALLEL/SERIAL OUT S.R.	18324	74HCT166D
U61	231131	IC, DIGITAL, SHIFT REGISTER	18324	PC74HCT164D
U62	231131	IC, DIGITAL, SHIFT REGISTER	18324	PC74HCT164D
U70	231152	IC, PROGRAMMED PLA	21793	231152
U71	231147	IC, MULTIPLEXER	04713	74HC253D
U72	231147	IC, MULTIPLEXER	04713	74HC253D
U80-U91	230774	IC, TRANSISTOR ARRAY	56289	ULN-2803A
U92	231299	IC, MODE SELECT PAL	21793	231299
U95	230414	IC, QUAD 2-INPUT EXCLUSIVE OR-GATES	01295	74L586
U96	231403	IC, DIGITAL, OCTAL BUFFER	01295	SN74HCT244N
U97	231130	IC, DIGITAL, FLIP FLOP	18324	PC74HC273
U99	231130	IC, DIGITAL, FLIP FLOP	18324	PC74HC273
U100	231131	IC, DIGITAL, SHIFT REGISTER	18324	PC74HCT164D
U102	231131	IC, DIGITAL, SHIFT REGISTER	18324	PC74HCT164D
U103	231298	IC, HANDSHAKE PAL	21793	231298
U107	231120	IC, 8-BIT, PARALLEL/SERIAL OUT S.R.	18324	74HCT166D
U109	231120	IC, 8-BIT, PARALLEL/SERIAL OUT S.R.	18324	74HCT166D
U117	231143	IC, HEX INVERTER	18324	74HCT14N
U118	231297	IC, PAL	21793	231297
U119-U130	231404	IC, DIGITAL, OCTAL RECEIVER	01295	SN74HCT6S2NT
U131-U154	231093	IC, QUAD COMPARATOR	04713	LM339D
U155	231219	IC, LINEAR, VREF	27014	LM38SBYZ
U156-U167	231236	IC, DIGITAL BUFFER 5010	04713	MC74HCT244DW
W1-W12	601935	CONNECTOR, HEADER, 10 PIN	52072	CA-D10-23B-43
Z25	080114	RES NETWORK, 16P8R, 15K	73138	628-AL-153J
Z26	080120	RES NETWORK, 10K	11236	767-161R1OK
Z56-Z67	080015	RES NETWORK, 10P9R, 10K, 5 PERCENT	71450	750-101-R1OK
{54}1	401951	PCB ASSY., LBUS JUMPER	21793	401951
{55}1	401951-003	PCB ASSY., P3 JUMPER	21793	401951-003
{56}1	415069	PCB, 1260-14C(UNLOADED)	21793	415069
{59}1	455776-001	PANEL, FRONT, 1260-140	21793	455776-001
{62}A/R	500022	WIRE, BARE COPPER/TIN, 22 GA	21793	500022

405069 PCB ASSY., 1260-14C

REF DESIG	RACAL INST P/N	DESCRIPTION	FSC	MANUFACTURER'S P/N
(64)12	601195	PLUG, JUMPER, 0.1CTR, LOW PROFILE	00779	530153-2
(71)1	601632	CONNECTOR, DIP, RECEPTACLE, 20P	00779	641612-4
(78)1	407179-001	PCB CABLE ASSY., 50-PIN	21793	407179-001
(79)1	407179-002	PCB CABLE ASSY., 50-PIN	21793	407179-002
(80)1	407180-001	PCB CABLE ASSY., 60-PIN	21793	407180-001
(81)1	407180-002	PCB CABLE ASSY., 60-PIN	21793	407180-002
{82}8	611023	KEY, POLARIZING CONNECTOR	06776	PK-3
(83)4	611258-001	STANDOFF, SWAGE 4-40 X .170	06540	8091-11B-B-440-28
(84)1	611264	HANDLE, EXTRACTOR, BOTTOM	62559	20817-327
(85)1	611265	HANDLE, EXTRACTOR, TOP	62559	20817-328
(86)0.5	611266	MOUNTING HARDWARE, HANDLE	62559	21100-745
(87)12	611060	CONNECTOR, DIP, 16 PIN, LOW PROFILE	91506	216-AG39D
(89)8	615545	SCREW, PFH, 4-40 X .500		
(91)2	616405	SCREW, PFH, M2.5- .45 X 12		
(93)8	617016	NUT, HEX, 4-40		
(94)8	617102	WASHER, FLAT, #4, LIGHT SERIES		
(95)8	617127	WASHER, LOCK, #4, LIGHT SERIES		
(96)12	920841	SOCKET, IC, 18-PIN, SOLDER TAIL	52072	CA-185-TSD-BC
{97}A/R	920962	LOCTITE, 242, MED STR.	05972	272
(98)1	921148-001	LABEL SET, VXI	21793	921148-001

## User Manual 1260-14C

---

407179-001 - CABLE ASSY., 50-PIN

REF DESIG	RACAL INST P/N	DESCRIPTION	FSC	MANUFACTURER'S P/N
(2)A/R	500272	CABLE, FLAT, RIBBON, 50 CONDUCTOR, 28GA	70903	9L28050
(3)1	601985	CONNECTOR, IDC SOCKET, SOP	53387	3425-6000
(4)1	601987	CONNECTOR, IDC PLUG, SOP	53387	4650-6300

407179-002 - CABLE ASSY., 50-PIN

REF DESIG	RACAL INST P/N	DESCRIPTION	FSC	MANUFACTURER'S P/N
{2}A/R	500272	CABLE, FLAT, RIBBON, 50 CONDUCTOR, 28GA	70903	9L28050
(3)1	601985	CONNECTOR, IDC SOCKET, SOP	53387	3425-6000
(4)1	601987	CONNECTOR, IOC PLUG, SOP	53387	4650-6300

407180-001 - CABLE ASSY., 60-PIN

REF DESIG	RACAL INST P/N	DESCRIPTION	FSC	MANUFACTURER'S P/N
(2)A/R	500253	CABLE, FLAT RIBBON, 60 COND	53387	3365/60
(3)1	601966	CONNECTOR, CABLE, FLAT, 60 PIN	53387	3334-6000
(4)1	601988	CONNECTOR, IDC PLUG, 60P	53387	4660-6300

407180-002 - CABLE ASSY., 60-PIN

REF DESIG	RACAL INST P/N	DESCRIPTION	FSC	MANUFACTURER'S P/N
(2)A/~	500253	CABLE, FLAT RIBBON, 60 COND	53387	3365/60
(3)1	601966	CONNECTOR, CABLE, FLAT, 60 PIN	53387	3334-6000
(4)1	601988	CONNECTOR, IDC PLUG, SOP	53387	4660-6300

404936-001 - SHIPPING KIT, 1260-14C

REF DESIG	RACAL INST P/N	DESCRIPTION	FSC	MANUFACTURER'S P/N
{1}2	455540	KEY, LOCKOUT, TTL, A/C	21793	455540
(2)2	455541	KEY, LOCKOUT, TTL, A/C	21793	455541
(3)2	455542	KEY, LOCKOUT, TTL, A/C	21793	455542
(5)3	615013	SCREW, PPF, 2-56 X .188		
(6)2	601457	CONNECTOR, FLAT CABLE, 60-PIN	52072	CA-601D52-F-SR
{7}2	601627	CONNECTOR, FLAT CABLE, RECEPTACLE, SOP	53387	3425-6050
{9}1	980673-012	INSTRUCTION MANUAL, 1260-14C	21793	980673-012

404974 CABLE ASSY., KIT , 1260-14

REF DESIG	RACAL INST P/N	DESCRIPTION	FSC	MANUFACTURER'S P/N
(1)1	404970	CABLE ASSY., J101	21793	404970
{2}1	404971	CABLE ASSY., J102	21793	404971
{3}1	404972	CABLE ASSY., J104	21793	404972
(4)1	404973	CABLE ASSY., J103	21793	404973

## User Manual 1260-14C

---

404970 CABLE ASSY., 1260-14-J101

REF DESIG	RACAL INST P/N	DESCRIPTION	FSC	MANUFACTURER'S P/N
{1}A/R	500292	CABLE, 50 CONDUCTORS, FLAT, TWISTED	53387	1700150
{2}1	601627	CONNECTOR, FLAT CABLE, RECEPTACLE, SOP	53387	3425-6050

404971 CABLE ASSY., 1260-14-J102

REF DESIG	RACAL INST P/N	DESCRIPTION	FSC	MANUFACTURER'S P/N
{1}2	500292	CABLE, 50 CONDUCTORS, FLAT, TWISTED	53387	700150
{2}1	601627	CONNECTOR, FLAT CABLE, RECEPTACLE, SOP	53387	3425-6050

404973 CABLE ASSY., 1260-14,J103

REF DESIG	RACAL INST P/N	DESCRIPTION	FSC	MANUFACTURER'S P/N
{1}A/R	500300	CABLE, 60 CONDUCTOR FLAT, TWISTED	52072	CA-60IDC-TF
{2}1	601457	CONNECTOR, FLAT CABLE, 60-PIN	52072	CA-601D52-SR

404972 CABLE ASSY., 1260-14, J104

REF DESIG	RACAL INST P/N	DESCRIPTION	FSC	MANUFACTURER'S P/N
{1}A/R	500300	CABLE, 60 CONDUCTOR FLAT, TWISTED	52072	CA-60IDC-TF
{2}1	601457	CONNECTOR, FLAT CABLE, 60-PIN	52072	CA-601D52-F-SR

## List of Suppliers

<b>FSC</b>	<b>SUPPLIER</b>
00779	AMP, INC. HARRISBURG, PA
01295	TEXAS INSTRUMENTS, INC. DALLAS, TX
02735	RCA (SOLID STATE DIV.) SOMERVILLE, NJ
04713	MOTOROLA, INC. (SEMICONDUCTOR PRODUCTS DIV.) PHOENIX, AZ
05397	UNION CARBIDE CORP. (MATERIALS SYSTEMS DIV.) CLEVELAND, OH
05972	LOCTITE CORP. HARTFORD, CT
06540	AMATOM ELECTRONIC HARDWARE NEW ROCHELLE, NY
06776	ROBINSON NUGENT INC. NEW ALBANY, IN
08261	SPECTRA-STRIP CORP. GARDEN GROVE, CA
11236	CTS OF BERNE, INC. BEPNE, IN
18324	SIGNETICS, INC. SUNNYVALE, CA
21793	RACAL INSTRUMENTS INC. IRVINE, CA
27014	NATIONAL SEMI-CONDUCTOR CORP. SANTA CLARA, CA
52072	CIRCUIT ASSY. CORP. COSTA MESA, CA
53387	THREE M (3M) CO. ST. PAUL, MN
55322	SAMTEC, INC NEW ALBANY, IN
62559	SCHROFF, INC. WARWICK, RI
65832	AMERICAN RESEARCH & ENGINEERING ELGIN, IL
73138	BECKMAN INSTRUMENTS FULLERTON, CA
91637	DALE ELECTRONICS, INC. COLUMBUS, NE
95275	VITRAMON, INC. BRIDGEPORT, CT

## Chapter 6

# OPTIONAL HARNESS ASSEMBLIES

---

The following harness assemblies are used to connect Racal Instruments Model 1260-14 to Freedom Series Test Receiver Interfaces.

Each harness documentation consists of an assembly drawing, parts list, system wire list and wire list.

407272          Virginia Panel, Inc. Series VP90 Interface Harness

407273          TTI Testron, Inc. Interface Harness

For more information on Racal Instruments complete line of Test Receivers Interface solution, contact your Sales Representative.

This page was intentionally left blank



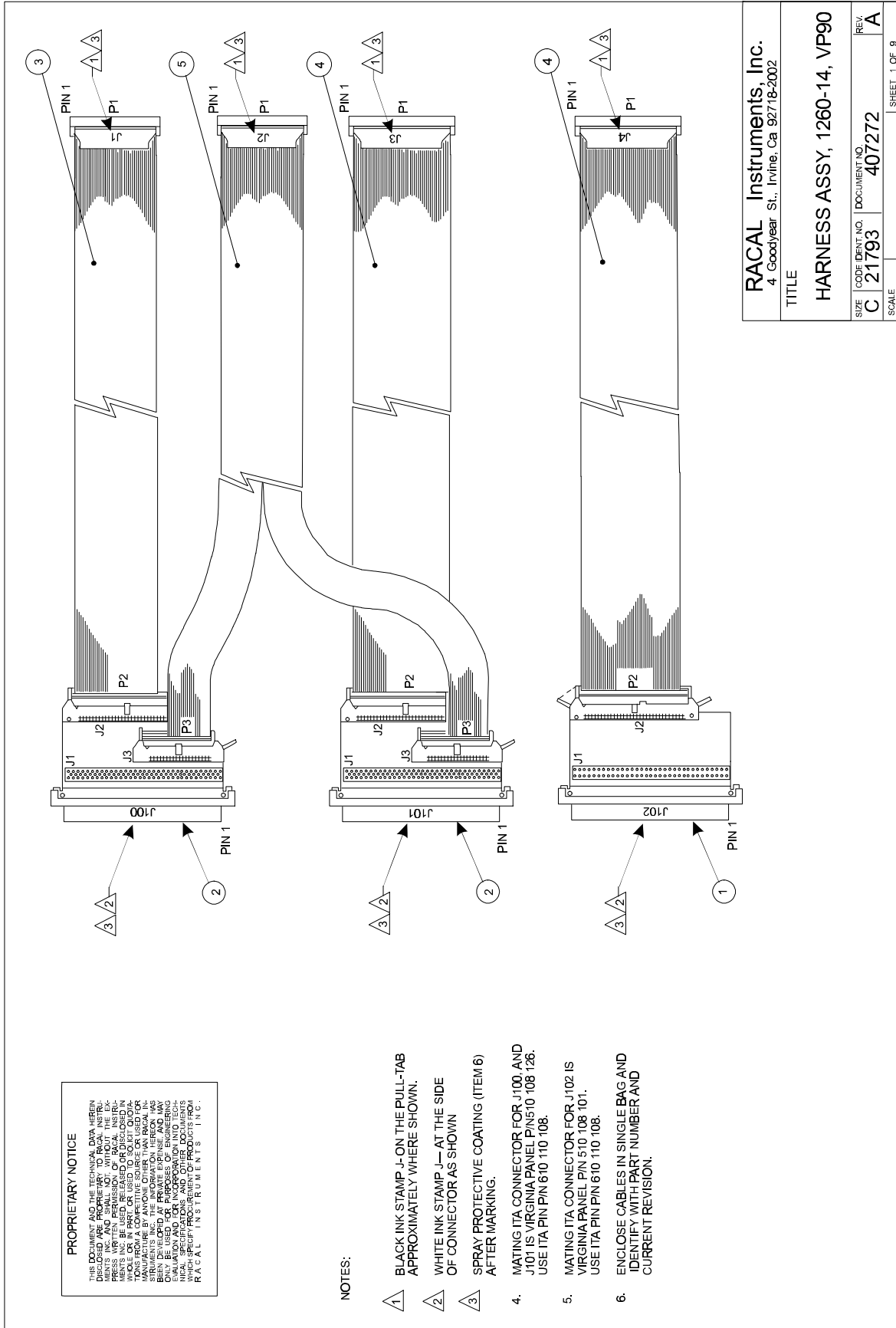

**PROPRIETARY NOTICE**  
 THIS DOCUMENT AND THE TECHNICAL DATA HEREIN DISCLOSED ARE PROPRIETARY TO RACAL INSTRUMENTS, INC. ANY REPRODUCTION, STORAGE, TRANSMISSION, OR DISSEMINATION OF THIS INFORMATION WITHOUT THE WRITTEN PERMISSION OF RACAL INSTRUMENTS, INC. IS PROHIBITED. RACAL INSTRUMENTS, INC. IS NOT RESPONSIBLE FOR REPRODUCTIONS FROM A COMPETITIVE SOURCE OR USED FOR OTHER THAN THE ORIGINAL INTENDED PURPOSE. RACAL INSTRUMENTS, INC. HAS BEEN DEVELOPED AT PRIVATE EXPENSE AND MAY BE SUBJECT TO PATENT AND TRADE SECRET PROTECTION AND FOR INCORPORATION INTO TECHNICAL INFORMATION. THE REQUIREMENTS OF THIS WHICH SPECIFY REQUIREMENT OF PRODUCTS FROM RACAL INSTRUMENTS, INC.

- NOTES:**
- 1 BLACK INK STAMP J- ON THE PULL-TAB APPROXIMATELY WHERE SHOWN.
  - 2 WHITE INK STAMP J- AT THE SIDE OF CONNECTOR AS SHOWN
  - 3 SPRAY PROTECTIVE COATING (ITEM 6) AFTER MARKING.
  - 4 MATING ITA CONNECTOR FOR J100 AND J101 IS VIRGINIA PANEL PIN510 108 126. USE ITA PIN PIN 610 110 108.
  - 5 MATING ITA CONNECTOR FOR J102 IS VIRGINIA PANEL PIN 510 108 101. USE ITA PIN PIN 610 110 108.
  - 6 ENCLOSE CABLES IN SINGLE BAG AND IDENTIFY WITH PART NUMBER AND CURRENT REVISION.

<b>RACAL Instruments, Inc.</b> 4 Goodyear St., Irvine, Ca 92718-2002	
TITLE <b>HARNESS ASSY, 1260-14, VP90</b>	
SIZE <b>C</b>	CODE IDENT. NO.   DOCUMENT NO. <b>21793   407272</b>
SCALE	REV.   SHEET 1 OF 9 <b>A</b>



### ENGINEERING PARTS LIST

WIRE	FROM	TO	TYPE	PART #	WIRE LEN	REFERENCE
	BLK AA (J100)	Uxx-SLOT yy (J1,J2)	CABLE	407272		SYSTEM WIRE LIST
	BLK AA (J101)	Uxx-SLOT yy (J2,J3)	CABLE	407272		
	BLK AA (J102)	Uxx-SLOT yy (J4)	CABLE	407272		

This system wirelist serves as a template for incorporating this harness assembly into the overall system wirelist. It does not in any way affect the fabrication of this harness assembly.

RACAL Instruments, Inc., 4 Goodyear St., Irvine, CA 92718				
DOCUMENT TITLE	SIZE.	CODE NO	DOCUMENT NO.	REV
HARNESS ASSY, 1260-14,VP90	A	21793	407272	A
DRN			SHEET 3 of 9	

**ENGINEERING WIRE LIST**

WIRE	FROM	TO	TYPE	PART #	WIRE LEN	REFERENCE
1	J100-96	J1-1	BRN	407251	41.5"	CHAN 01
2	J100-32	J1-2	TAN	407251	41.5"	CHAN 01 RTN
3	J100-64	J1-3	RED	407251	41.5"	CHAN 02
4	J100-95	J1-4	TAN	407251	41.5"	CHAN 02 RTN
5	J100-31	J1-5	ORN	407251	41.5"	CHAN 03
6	J100-63	J1-6	TAN	407251	41.5"	CHAN 03 RTN
7	J100-94	J1-7	YEL	407251	41.5"	CHAN 04
8	J100-30	J1-8	TAN	407251	41.5"	CHAN 04 RTN
9	J100-62	J1-9	ORN	407251	41.5"	CHAN 05
10	J100-93	J1-10	TAN	407251	41.5"	CHAN 05 RTN
11	J100-29	J1-11	BLU	407251	41.5"	CHAN 06
12	J100-61	J1-12	TAN	407251	41.5"	CHAN 06 RTN
13	J100-92	J1-13	VIO	407251	41.5"	CHAN 07
14	J100-28	J1-14	TAN	407251	41.5"	CHAN 07 RTN
15	J100-60	J1-15	GRY	407251	41.5"	CHAN 08
16	J100-91	J1-16	TAN	407251	41.5"	CHAN 08 RTN
17	J100-27	J1-17	WRT	407251	41.5"	CHAN 09
18	J100-59	J1-18	TAN	407251	41.5"	CHAN 09 RTN
19	J100-90	J1-19	BLK	407251	41.5"	CHAN 10
20	J100-26	J1-20	TAN	407251	41.5"	CHAN 10 RTN
21	J100-58	J1-21	BRN	407251	41.5"	CHAN 11
22	J100-89	J1-22	TAN	407251	41.5"	CHAN 11 RTN
23	J100-25	J1-23	RED	407251	41.5"	CHAN 12
24	J100-57	J1-24	TAN	407251	41.5"	CHAN 12 RTN
25	J100-88	J1-25	ORN	407251	41.5"	CHAN 13
26	J100-24	J1-26	TAN	407251	41.5"	CHAN 13 RTN
27	J100-56	J1-27	YEL	407251	41.5"	CHAN 14
28	J100-87	J1-28	TAN	407251	41.5"	CHAN 14 RTN
29	J100-23	J1-29	GRN	407251	41.5"	CHAN 15
30	J100-55	J1-30	TAN	407251	41.5"	CHAN 15 RTN
31	J100-86	J1-31	BLU	407251	41.5"	CHAN 16
32	J100-22	J1-32	TAN	407251	41.5"	CRAN 16 RTN
33	J100-54	J1-33	VIO	407251	41.5"	CHAN 17
34	J100-85	J1-34	TAN	407251	41.5"	CHAN 17 RTN
35	J100-21	J1-35	GRY	407251	41.5"	CHAN 18
36	J100-53	J1-36	TAN	407251	41.5"	CHAN 18 RTN
37	J100-84	J1-37	WHT	407251	41.5"	CHAN 19
38	J100-20	J1-38	TAN	407251	41.5"	CHAN 19 RTN
39	J100-52	J1-39	BLK	407251	41.5"	CHAN 20
40	J100-83	J1-40	TAN	407251	41.5"	CHAN 20 RTN
41	J100-19	J1-41	BRN	407251	41.5"	CHAN 21
42	J100-51	J1-42	TAN	407251	41.5"	CHAN 21 RTN
43	J100-82	J1-43	RED	407251	41.5"	CHAN 22
44	J100-18	J1-44	TAN	407251	41.5"	CHAN 22 RTN
45	J100-50	J1-45	ORN	407251	41.5"	CHAN 23
46	J100-81	J1-46	TAN	407251	41.5"	CHAN 23 RTN
47	J100-17	J1-47	YEL	407251	41.5"	CHAN 24
48	J100-49	J1-48	TAN	407251	41.5"	CHAN 24 RTN
49	J100-80	J1-49	GRN	407251	41.5"	BUSY
50	J100-16	J1-50	TAN	407251	41.5"	GND

RACAL Instruments, Inc., 4 Goodyear St., Irvine, CA 92718

DOCUMENT TITLE	SIZE.	CODE NO	DOCUMENT NO.	REV
HARNESS ASSY, 1260-14,VP90	A	21793	407272	A
	DRN			SHEET 4 of 9

**ENGINEERING WIRE LIST**

WIRE	FROM	TO	TYPE	PART #	WIRE LEN	REFERENCE
51 52	J100-48 J100-79	NO CONNECT NO CONNECT				
53 54	J100-15 J100-47	NO CONNECT NO CONNECT				
55 56	J100-78 J100-14	NO CONNECT NOCONNECT				
57 58	J100-46 J100-77	NO CONNECT NO CONNECT				
59 60	J100-13 J100-45	NO CONNECT NO CONNECT				
61 62	J100-76 J100-12	NO CONNECT NO CONNECT				
63 64	J100-44 J100-75	NO CONNECT NO CONNECT				
65 66	J100-11 J100-43	NO CONNECT NO CONNECT				
67 68	J100-74 J100-10	NO CONNECT NO CONNECT				
69 70	J100-42 J100-73	NO CONNECT NO CONNECT				
71 72	J100-9 J100-41	J2-1 J2-2	BRN TAN	407252 407252	41.5" 41.5"	CHAN 25 CHAN 25 RTN
73 74	J100-72 J100-8	J2-3 J2-4	RED TAN	407252 407252	41.5" 41.5"	CHAN 26 CHAN 26 RTN
75 76	J100-40 J100-71	J2-5 J2-6	ORN TAN	407252 407252	41.5" 41.5"	CHAN 27 CHAN 27 RTN
77 78	J100-7 J100-39	J2-7 J2-8	YEL TAN	407252 407252	41.5" 41.5"	CHAN 28 CHAN 28 RTN
79 80	J100-70 J100-6	J2-9 J2-10	GRN TAN	407252 407252	41.5" 41.5"	CHAN 29 CHAN 29 RTN
81 82	J100-38 J100-69	J2-11 J2-12	BLU TAN	407252 407252	41.5" 41.5"	CHAN 30 CHAN 30 RTN
83 84	J100-5 J100-37	J2-13 J2-14	VIO TAN	407252 407252	41.5" 41.5"	CHAN 31 CHAN 31 RTN
85 86	J100-68 J100-4	J2-15 J2-16	GRY TAN	407252 407252	41.5" 41.5"	CHAN 32 CHAN 32 RTN
87 88	J100-36 J100-67	J2-17 J2-18	WHT TAN	407252 407252	41.5" 41.5"	CHAN 33 CHAN 33 RTN
89 90	J100-3 J100-35	J2-19 J2-20	BLK TAN	407252 407252	41.5" 41.5"	CHAN 34 CHAN 34 RTN
91 92	J100-66 J100-2	J2-21 J2-22	BRN TAN	407252 407252	41.5" 41.5"	CHAN 35 CHAN 35 RTN
93 94	J100-34 J100-65	J2-23 J2-24	RED TAN	407252 407252	41.5" 41.5"	CHAN 36 CHAN 36 RTN
95 96	J100-1 J100-33	J2-25 J2-26	ORN TAN	407252 407252	41.5" 41.5"	CHAN 37 CHAN 37 RTN

RACAL Instruments, Inc., 4 Goodyear St., Irvine, CA 92718

DOCUMENT TITLE	SIZE.	CODE NO	DOCUMENT NO.	REV
HARNES ASSY, 1260-14,VP90	A	21793	407272	A
DRN			SHEET 5 of 9	

**ENGINEERING WIRE LIST**

WIRE	FROM	TO	TYPE	PART #	WIRE LEN	REFERENCE
97	J101-72	J2-27	YEL	407252	41.5"	CHAN 38
98	J101-8	J2-28	TAN	407252	41.5"	CHAN 38 RTN
99	J101-140	J2-29	GRN	407252	41.5"	CHAN 39
100	J101-71	J2-30	TAN	407252	41.5"	CHAN 39 RTN
101	J101-7	J2-31	BLU	407252	41.5"	CHAN 40
102	J101-39	J2-32	TAN	407252	41.5"	CHAN 40 RTN
103	J101-70	J2-33	VIO	407252	41.5"	CHAN 41
104	J101-6	J2-34	TAN	407252	41.5"	CHAN 41 RTN
105	J101-38	J2-35	GRY	407252	41.5"	CHAN 42
106	J101-69	J2-36	TAN	407252	41.5"	CHAN 42 RTN
107	J101-5	J2-37	WHT	407252	41.5"	CHAN 43
108	J101-37	J2-38	TAN	407252	41.5"	CHAN 43 RTN
109	J101-68	J2-39	BLK	407252	41.5"	CHAN 44
110	J101-4	J2-40	TAN	407252	41.5"	CHAN 44 RTN
111	J101-36	J2-41	BRN	407252	41.5"	CHAN 45
112	J101-67	J2-42	TAN	407252	41.5"	CHAN 45 RTN
113	J101-3	J2-43	RED	407252	41.5"	CHAN 46
114	J101-35	J2-44	TAN	407252	41.5"	CHAN 46 RTN
115	J101-66	J2-45	ORN	407252	41.5"	CHAN 47
116	J101-2	J2-46	TAN	407252	41.5"	CHAN 47 RTN
117	J101-34	J2-47	YEL	407252	41.5"	CHAN 48
118	J101-65	J2-48	TAN	407252	41.5"	CHAN 48 RTN
119	J101-1	J2-49	GRN	407252	41.5"	CLOCK IN
120	J101-3;	J2-50	TAN	407252	41.5"	CLOCK IN RTN
121	J101-96	J3-1	BRN	407256	41.5"	CHAN 49
122	J101-32	J3-2	TAN	407256	41.5"	CHAN 49 RTN
123	J101-64	J3-3	RED	407256	41.5"	CHAN 50
124	J101-95	J3-4	TAN	407256	41.5"	CHAN 50 RTN
125	J101-31	J3-5	ORN	407256	41.5"	CHAN 51
126	J101-63	J3-6	TAN	407256	41.5"	CHAN 51 RTN
127	J101-94	J3-7	YEL	407256	41.5"	CHAN 52
128	J101-30	J3-8	TAN	407256	41.5"	CHAN 52 RTN
129	J101-62	J3-9	GRN	407256	41.5"	CHAN 53
130	J101-93	J3-10	TAN	407256	41.5"	CHAN 53 RTN
131	J101-29	J3-11	BLU	407256	41.5"	CHAN 54
132	J101-61	J3-12	TAN	407256	41.5"	CHAN 54 RTN
133	J101-92	J3-13	VIO	407256	41.5"	CHAN 55
134	J101-28	J3-14	TAN	407256	41.5"	CHAN 55 RTN
135	J101-60	J3-15	GRY	407256	41.5"	CHAN 56
136	J101-91	J3-16	TAN	407256	41.5"	CHAN 56 RTN
137	J101-27	J3-17	WHT	407256	41.5"	CHAN 57
138	J101-59	J3-18	TAN	407256	41.5"	CHAN 57 RTN
139	J101-90	J3-19	BLK	407256	41.5"	CHAN 58
140	J101-26	J3-20	TAN	407256	41.5"	CHAN 58 RTN
141	J101-58	J3-21	BRN	407256	41.5"	CHAN 59
142	J101-89	J3-22	TAN	407256	41.5"	CHAN 59 RTN
143	J101-25	J3-23	RED	407256	41.5"	CHAN 60
144	J101-57	J3-24	TAN	407256	41.5"	CHAN 60 RTN

RACAL Instruments, Inc., 4 Goodyear St., Irvine, CA 92718

DOCUMENT TITLE	SIZE.	CODE NO	DOCUMENT NO.	REV
HARNESS ASSY, 1260-14,VP90	A	21793	407272	A
	DRN			SHEET 6 of 9

**ENGINEERING WIRE LIST**

WIRE	FROM	TO	TYPE	PART #	WIRE LEN	REFERENCE
145	J101-88	J3-25	ORN	407256	41.5"	CHAN 61
146	J101-24	J3-26	TAN	407256	41.5"	CHAN 61 RTN
147	J101-56	J3-27	YEL	407256	41.5"	CHAN 62
148	J101-87	J3-28	TAN	407256	41.5"	CHAN 62 RTN
149	J101-23	J3-29	ORN	407256	41.5"	CHAN 63
150	J101-55	J3-30	TAN	407256	41.5"	CHAN 63 RTN
151	J101-86	J3-31	BLU	407256	41.5"	CHAN 64
152	J101-22	J3-32	TAN	407256	41.5"	CHAN 64 RTN
153	J101-54	J3-33	VIO	407256	41.5"	CHAN 65
154	J101-85	J3-34	TAN	407256	41.5"	CHAN 65 RTN
155	J101-21	J3-35	GRY	407256	41.5"	CHAN 66
156	J101-53	J3-36	TAN	407256	41.5"	CHAN 66 RTN
157	J101-84	J3-37	WHT	407256	41.5"	CHAN 67
158	J101-20	J3-38	TAN	407256	41.5"	CHAN 67 RTN
159	J101-52	J3-39	BLK	407256	41.5"	CHAN 68
160	J101-83	J3-40	TAN	407256	41.5"	CHAN 68 RTN
161	J101-19	J3-41	BRN	407256	41.5"	CHAN 69
162	J101-51	J3-42	TAN	407256	41.5"	CHAN 69 RTN
163	J101-82	J3-43	RED	407256	41.5"	CHAN 70
164	J101-18	J3-44	TAN	407256	41.5"	CHAN 70 RTN
165	J101-50	J3-45	ORN	407256	41.5"	CIAN 71
166	J101-81	J3-46	TAN	407256	41.5"	CHAN 71 RTN
167	J101-17	J3-47	YEL	407256	41.5"	CHAN 72
168	J101-49	J3-48	TAN	407256	41.5"	CHAN 72 RTN
169	J101-80	J3-49	GRN	407256	41.5"	EDRVR 00/VEXT 01
170	J101-16	J3-50	TAN	407256	41.5"	EDRVR 00/VEXT 01 RTN
171	J101-48	J3-51	BLU	407256	41.5"	EDRVR 01/VEXT 02
172	J101-79	J3-52	TAN	407256	41.5"	EDRVR 01/VEXT 02 RTN
173	J101-15	J3-53	VIO	407256	41.5"	EDRVR 02/VEXT 03
174	J101-47	J3-54	TAN	407256	41.5"	EDRVR 02/VEXT 03 RTN
175	J101-78	J3-55	GRY	407256	41.5"	EDRVR 03/VEXT 04
176	J101-14	J3-56	TAN	407256	41.5"	EDRVR 03/VEXT 04 RTN
177	J101-46	J3-57	WHT	407256	41.5"	EDRVR 04/VEXT 05
178	J101-77	J3-58	TAN	407256	41.5"	EDRVR 04/VEXT 05 RTN
179	J101-13	J3-59	BLK	407256	41.5"	EDRVR 05/VEXT 06
180	J101-45	J3-60	TAN	407256	41.5"	EDRVR 05/VEXT 06 RTN
181	J101-76	NO CONNECT				
182	J101-12	NO CONNECT				
183	J101-44	NO CONNECT				
184	J101-75	NO CONNECT				
185	J101-11	NO CONNECT				
186	J101-43	NO CONNECT				
187	J101-74	NO CONNECT				
188	J101-10	NO CONNECT				
189	J101-42	NO CONNECT				
190	J101-73	NO CONNECT				
191	J101-9	NO CONNECT				
192	J101-41	NO CONNECT				

RACAL Instruments, Inc., 4 Goodyear St., Irvine, CA 92718

DOCUMENT TITLE	SIZE.	CODE NO	DOCUMENT NO.	REV
HARNES ASSY, 1260-14,VP90	A	21793	407272	A
DRN			SHEET 7 of 9	

## ENGINEERING WIRE LIST

WIRE	FROM	TO	TYPE	PART #	WIRE LEN	REFERENCE
193	J102-64	J4-1	BRN	407256	41.5"	CHAN 73
194	J102-32	J4-2	TAN	407256	41.5"	CHAN 73 RTN
195	J102-63	J4-3	RED	407256	41.5"	CHAN 74
196	J102-31	J4-4	TAN	407256	41.5"	CHAN 74 RTN
197	J102-62	J4-5	ORN	407256	41.5"	CHAN 75
198	J102-30	J4-6	TAN	407256	41.5"	CHAN 75 RTN
199	J102-61	J4-7	YEL	407256	41.5"	CHAN 76
200	J102-29	J4-8	TAN	407256	41.5"	CHAN 76 RTN
201	J102-60	J4-9	GRN	407256	41.5"	CHAN 77
202	J102-28	J4-10	TAN	407256	41.5"	CHAN 77 RTN
203	J102-59	J4-11	BLU	407256	41.5"	CHAN 78
204	J102-27	J4-12	TAN	407256	41.5"	CHAN 78 RTN
205	J102-58	J4-13	VIO	407256	41.5"	CHAN 79
206	J102-26	J4-14	TAN	407256	41.5"	CHAN 79 RTN
207	J102-57	J4-15	GRY	407256	41.5"	CHAN 80
208	J102-25	J4-16	TAN	407256	41.5"	CHAN 80 RTN
209	J102-56	J4-17	WHT	407256	41.5"	CHAN 81
210	J102-24	J4-18	TAN	407256	41.5"	CHAN 81 RTN
211	J102-55	J4-19	BLK	407256	41.5"	CHAN 82
212	J102-23	J4-20	TAN	407256	41.5"	CHAN 82 RTN
213	J102-54	J4-21	BRN	407256	41.5"	CHAN 83
214	J102-22	J4-22	TAN	407256	41.5"	CHAN 83 RTN
215	J102-53	J4-23	RED	407256	41.5"	CHAN 84
216	J102-21	J4-24	TAN	407256	41.5"	CHAN 84 RTN
217	J102-52	J4-25	ORN	407256	41.5"	CHAN 85
218	J102-20	J4-26	TAN	407256	41.5"	CHAN 85 RTN
219	J102-51	J4-27	YEL	407256	41.5"	CHAN 86
220	J102-19	J4-28	TAN	407256	41.5"	CHAN 86 RTN
221	J102-50	J4-29	GRN	407256	41.5"	CHAN 87
222	J102-18	J4-30	TAN	407256	41.5"	CHAN 87 RTN
223	J102-49	J4-31	BLU	407256	41.5"	CHAN 88
224	J102-17	J4-32	TAN	407256	41.5"	CHAN 88 RTN
225	J102-48	J4-33	VIO	407256	41.5"	CHAN 89
226	J102-16	J4-34	TAN	407256	41.5"	CHAN 89 RTN
227	J102-47	J4-35	GRY	407256	41.5"	CHAN 90
228	J102-15	J4-36	TAN	407256	41.5"	CHAN 90 RTN
229	J102-46	J4-37	WHT	407256	41.5"	CHAN 91
230	J102-14	J4-38	TAN	407256	41.5"	CHAN 91 RTN
231	J102-45	J4-39	BLK	407256	41.5"	CHAN 92
232	J102-13	J440	TAN	407256	41.5"	CHAN 92 RTN
233	J102-44	J441	BRN	407256	41.5"	CHAN 93
234	J102-12	J442	TAN	407256	41.5"	CHAN 93 RTN
235	J102-43	J443	RED	407256	41.5"	CHAN 94
236	J102-11	J444	TAN	407256	41.5"	CHAN 94 RTN
237	J102-42	J4-45	ORN	407256	41.5"	CHAN 95
238	J102-10	J446	TAN	407256	41.5"	CHAN 95 RTN
239	J102-41	J447	YEL	407256	41.5"	CHAN 96
240	J102-9	J448	TAN	407256	41.5"	CHAN 96 RTN
241	J102-40	J449	GRN	407256	41.5"	EDRVR 06/VEXT 07
242	J102-8	J4-50	TAN	407256	41.5"	EDRVR 06/VEXT 07 RTN

RACAL Instruments, Inc., 4 Goodyear St., Irvine, CA 92718

DOCUMENT TITLE	SIZE.	CODE NO	DOCUMENT NO.	REV
HARNESS ASSY, 1260-14,VP90	A	21793	407272	A
DRN			SHEET 8 of 9	



## ENGINEERING WIRE LIST

WIRE	FROM	TO	TYPE	PART #	WIRE LEN	REFERENCE
243 244	J102-39 J102-7	J4-51 J4-52	BLU TAN	407256 407256	41.5" 41.5"	EDRVR 07/VEXT 08 EDRVR 07/VEXT 08 RTN
245 246	J102-38 J102-6	J4-53 J4-54	VIO TAN	407256 407256	41.5" 41.5"	EDRVR 08/VEXT 09 EDRVR 08/VEXT 09 RTN
247 248	J102-37 J102-5	J4-55 J4-56	GRY TAN	407256 407256	41.5" 41.5"	EDRVR 09/VEXT 10 EDRVR 09/VEXT 10 RTN
249 250	J102-36 J1024	J4-57 J4-58	WHT TAN	407256 407256	41.5" 41.5"	EDRVR 10/VEXT 11 EDRVR 10/VENT 11 RTN
251 252	J102-35 J102-3	J4-59 J4-60	BLK TAN	407256 407256	41.5" 41.5"	EDRVR 11/VEXT 12 EDRVR 11/VEXT 12 RTN
253 254	J102-34 J102-2	NO CONNECT NO CONNECT				
255 256	J102-33 J102-1	NO CONNECT NO CONNECT				

RACAL Instruments, Inc., 4 Goodyear St., Irvine, CA 92718				
DOCUMENT TITLE	SIZE	CODE NO	DOCUMENT NO.	REV
HARNESS ASSY, 1260-14,VP90	A	21793	407272	A
DRN			SHEET 9 of 9	



**ENGINEERING PARTS LIST**

ITEM	BIN	PART NO.	DESCRIPTION	QTY	REFERENCE
1		407250	CABLE ASSY, IDC, 50-COND, TTI	2	
2		407255	CABLE ASSY, IDC, 60-COND, TTI	2	
3		610777	TIE-CA-LKG-.062-.075	A/R	
4		910541	POLYURETHANE CONFORMAL COAT	A/R	

RACAL Instruments, Inc., 4 Goodyear St., Irvine, CA 92718				
DOCUMENT TITLE	SIZE	CODE NO	DOCUMENT NO.	REV
HARNESS ASSY, 1260-14,TTI	A	21793	407273	A
	DRN		SHEET 2 of 8	

**ENGINEERING WIRE LIST**

WIRE	FROM	TO	TYPE	PART #	WIRE LEN	REFERENCE
	BLK AAx RW 01 (J100)	Uxx-SLOT yy (J1)	CABLE	407273		SYSTEM WIRE LIST
	BLK AAx RW 02 (3101)	Uxx-SLOT yy (J1)	CABLE	407273		
	BLK AAx RW 03 (J102)	Uxx-SLOT yy (J1)	CABLE	407273		
	BLK AAx RW 04 (J103)	Uxx-SLOT yy (J1)	CABLE	407273		
	BLK AAx RW 05 (J104)	Uxx-SLOT yy (J1)	CABLE	407273		
	BLK AAx RW 06 (J105)	Uxx-SLOT yy (J2)	CABLE	407273		
	BLK AAx RW 07 (J106)	Uxx-SLOT yy (J2)	CABLE	407273		
	BLK AAx RW 08 (J107)	Uxx-SLOT yy (J2)	CABLE	407273		
	BLK AAx RW 09 (J108)	Uxx-SLOT yy (J2)	CABLE	407273		
	BLK AAx RW 10 (J109)	Uxx-SLOT yy (J2)	CABLE	407273		
	BLK AAx RW 11 (J110)	Uxx-SLOT yy (J3)	CABLE	407273		
	BLK AAx RW 12 (J111)	Uxx-SLOT yy (J3)	CABLE	407273		
	BLK AAx RW 13 (J112)	Uxx-SLOT yy (J3)	CABLE	407273		
	BLK AAx RW 14 (J113)	Uxx-SLOT yy (J3)	CABLE	407273		
	BLK AAx RW 15 (J114)	Uxx-SLOT yy (J3)	CABLE	407273		
	BLK AAx RW 16 (J115)	Uxx-SLOT yy (J3)	CABLE	407273		
	BLK AAx RW 17 (J116)	Uxx-SLOT yy (J4)	CABLE	407273		
	BLK AAx RW 01 (J117)	Uxx-SLOT yy (J4)	CABLE	407273		
	BLK AAx RW 02 (J118)	Uxx-SLOT yy (J4)	CABLE	407273		
	BLK AAx RW 03 (J119)	Uxx-SLOT yy (J4)	CABLE	407273		
	BLK AAx RW 04 (J120)	Uxx-SLOT yy (J4)	CABLE	407273		
	BLK AAx RW 05 (J121)	Uxx-SLOT yy (J4)	CABLE	407273		

This system wirelist serves as a template for incorporating this harness assembly into the overall system wirelist. It does not in any way affect the fabrication of this harness assembly.

RACAL Instruments, Inc., 4 Goodyear St., Irvine, CA 92718

DOCUMENT TITLE	SIZE	CODE NO	DOCUMENT NO.	REV
HARNESS ASSY, 1260-14,TTI	A	21793	407273	A
DRN			SHEET 3 of 8	

**ENGINEERING WIRE LIST**

WIRE	FROM	TO	TYPE	PART #	WIRE LEN	REFERENCE
1	J100-1	J1-1	BRN	407250	41.5"	CHAN 01
2	J100-2	J1-2	TAN	407250	41.5"	CHAN 01 RTN
3	J100-3	J1-3	RED	407250	41.5"	CHAN 02
4	J100-4	J1-4	TAN	407250	41.5"	CHAN 02 RTN
5	J100-5	J1-5	ORN	407250	41.5"	CHAN 03
6	J100-6	J1-6	TAN	407250	41.5"	CHAN 03 RTN
7	J100-7	J1-7	YEL	407250	41.5"	CHAN 04
8	J100-8	J1-8	TAN	407250	41.5"	CHAN 04 RTN
9	J100-9	J1-9	GRN	407250	41.5"	CHAN 05
10	J100-10	J1-10	TAN	407250	41.5"	CHAN 05 RTN
11	J101-10	J1-11	BLU	407250	41.5"	CHAN 06
12	J101-9	J1-12	TAN	407250	41.5"	CHAN 06 RTN
13	J101-8	J1-13	VIO	407250	41.5"	CHAN 07
14	J101-7	J1-14	TAN	407250	41.5"	CHAN 07 RTN
15	J101-6	J1-15	GRY	407250	41.5"	CHAN 08
16	J101-5	J1-16	TAN	407250	41.5"	CHAN 08 RTN
17	J101-4	J1-17	WHT	407250	41.5"	CHAN 09
18	J101-3	J1-18	TAN	407250	41.5"	CHAN 09 RTN
19	J101-2	J1-19	BLK	407250	41.5"	CHAN 10
20	J101-1	J1-20	TAN	407250	41.5"	CHAN 10 RTN
21	J102-1	J1-21	BRN	407250	41.5"	CHAN 11
22	J102-2	J1-22	TAN	407250	41.5"	CHAN 11 RTN
23	J102-3	J1-23	RED	407250	41.5"	CHAN 12
24	J102-4	J1-24	TAN	407250	41.5"	CHAN 12 RTN
25	J102-5	J1-25	ORN	407250	41.5"	CHAN 13
26	J102-6	J1-26	TAN	407250	41.5"	CHAN 13 RTN
27	J102-7	J1-27	YEL	407250	41.5"	CHAN 14
28	J102-8	J1-28	TAN	407250	41.5"	CHAN 14 RTN
29	J102-9	J1-29	GRN	407250	41.5"	CHAN 15
30	J102-10	J1-30	TAN	407250	41.5"	CHAN 15 RTN
31	J103-10	J1-31	BLU	407250	41.5"	CHAN 16
32	J103-9	J1-32	TAN	407250	41.5"	CHAN 16 RTN
33	J103-8	J1-33	VIO	407250	41.5"	CHAN 17
34	J103-7	J1-34	TAN	407250	41.5"	CHAN 17 RTN
35	J103-6	J1-35	GRY	407250	41.5"	CHAN 18
36	J103-5	J1-36	TAN	407250	41.5"	CHAN 18 RTN
37	J103-4	J1-37	WHT	407250	41.5"	CHAN 19
38	J103-3	J1-38	TAN	407250	41.5"	CHAN 19 RTN
39	J103-2	J1-39	BLK	407250	41.5"	CHAN 20
40	J103-1	J1-40	TAN	407250	41.5"	CHAN 20 RTN
41	J104-1	J1-41	BRN	407250	41.5"	CHAN 21
42	J104-2	J1-42	TAN	407250	41.5"	CHAN 21 RTN
43	J104-3	J1-43	RED	407250	41.5"	CHAN 22
44	J104-4	J1-44	TAN	407250	41.5"	CHAN 22 RTN
45	J104-5	J1-45	ORN	407250	41.5"	CHAN 23
46	J104-6	J1-46	TAN	407250	41.5"	CHAN 23 RTN
47	J104-7	J1-47	YEL	407250	41.5"	CHAN 24
48	J104-8	J1-48	TAN	407250	41.5"	CHAN 24 RTN
49	J104-9	J1-49	GRN	407250	41.5"	BUSY
50	J104-10	J1-50	TAN	407250	41.5"	GND

RACAL Instruments, Inc., 4 Goodyear St., Irvine, CA 92718				
DOCUMENT TITLE	SIZE	CODE NO	DOCUMENT NO.	REV
HARNESS ASSY, 1260-14,TTI	A	21793	407273	A
DRN			SHEET 4 of 8	

## ENGINEERING WIRE LIST

WIRE	FROM	TO	TYPE	PART #	WIRE LEN	REFERENCE
51	J105-1	J2-1	BRN	407250	41.5"	CHAN2S
52	J105-2	J2-2	TAN	407250	41.5"	CHAN 25 RTN
53	J105-3	J2-3	RED	407250	41.5"	CHAN 26
54	J105-4	J2-4	TAN	407250	41.5"	CHAN 26 RTN
55	J105-5	J2-5	ORN	407250	41.5"	CHAN 27
56	J105-6	J2-6	TAN	407250	41.5"	CHAN 27 RTN
57	J105-7	J2-7	YEL	407250	41.5"	CHAN 28
58	J105-8	J2-8	TAN	407250	41.5"	CHAN 28 RTN
59	J105-9	J2-9	GRN	407250	41.5"	CHAN 29
60	J105-10	J2-10	TAN	407250	41.5"	CHAN 29 RTN
61	J106-10	J2-11	BLU	407250	41.5"	CHAN 30
62	J106-9	J2-12	TAN	407250	41.5"	CHAN 30 RTN
63	J106-8	J2-13	VIO	407250	41.5"	CHAN 31
64	J106-7	J2-14	TAN	407250	41.5"	CHAN 31 RTN
65	J106-6	J2-15	GRY	407250	41.5"	CHAN 32
66	J106-5	J2-16	TAN	407250	41.5"	CHAN 32 RTN
67	J106-4	J2-17	WHT	407250	41.5"	CHAN 33
68	J106-3	J2-18	TAN	407250	41.5"	CHAN 33 RTN
69	J106-2	J2-19	BLK	407250	41.5"	CHAN 34
70	J106-1	J2-20	TAN	407250	41.5"	CHAN 34 RTN
71	J107-1	J2-21	BRN	407250	41.5"	CHAN 35
72	J107-2	J2-22	TAN	407250	41.5"	CHAN 35 RTN
73	J107-3	J2-23	RED	407250	41.5"	CHAN 36
74	J107-4	J2-24	TAN	407250	41.5"	CHAN 36 RTN
75	J107-5	J2-25	ORN	407250	41.5"	CHAN 37
76	J107-6	J2-26	TAN	407250	41.5"	CHAN 37 RTN
77	J107-7	J2-27	YEL	407250	41.5"	CHAN 38
78	J107-8	J2-28	TAN	407250	41.5"	CHAN 38 RTN
79	J107-9	J2-29	GRN	407250	41.5"	CHAN 39
80	J107-10	J2-30	TAN	407250	41.5"	CHAN 39 RTN
81	J108-10	J2-31	BLU	407250	41.5"	CHAN 40
82	J108-9	J2-32	TAN	407250	41.5"	CHAN 40 RTN
83	J108-8	J2-33	VIO	407250	41.5"	CHAN 41
84	J108-7	J2-34	TAN	407250	41.5"	CHAN 41 RTN
85	J108-6	J2-35	GRY	407250	41.5"	CHAN 42
86	J108-5	J2-36	TAN	407250	41.5"	CHAN 42 RTN
87	J108-4	J2-37	WHT	407250	41.5"	CHAN 43
88	J108-3	J2-38	TAN	407250	41.5"	CHAN 43 RTN
89	J108-2	J2-39	BLK	407250	41.5"	CHAN 44
90	J108-1	J2-40	TAN	407250	41.5"	CHAN 44 RTN
91	J109-1	J2-41	BRN	407250	41.5"	CHAN 45
92	J109-2	J2-42	TAN	407250	41.5"	CHAN 45 RTN
93	J109-3	J2-43	RED	407250	41.5"	CHAN 46
94	J109-4	J2-44	TAN	407250	41.5"	CHAN 46 RTN
95	J109-5	J2-45	ORN	407250	41.5"	CHAN 47
96	J109-6	J2-46	TAN	407250	41.5"	CHAN 47 RTN
97	J109-7	J2-47	YEL	407250	41.5"	CHAN 48
98	J109-8	J2-48	TAN	407250	41.5"	CHAN 48 RTN

RACAL Instruments, Inc., 4 Goodyear St., Irvine, CA 92718

DOCUMENT TITLE	SIZE	CODE NO	DOCUMENT NO.	REV
HARNESS ASSY, 1260-14,TTI	A	21793	407273	A
	DRN		SHEET 5 of 8	

**ENGINEERING WIRE LIST**

WIRE	FROM	TO	TYPE	PART #	WIRE LEN	REFERENCE
99 100	J109-9 J109-10	J2-49 J2-50	ORN TAN	407250 407250	41.5" 41.5"	CLOCK IN CLOCK IN RTN
101 102	J110-1 J110-2	J3-1 J3-2	BRN TAN	407255 407255	41.5" 41.5"	CHAN 49 CHAN 49 RTN
103 104	J110-3 J110-4	J3-3 J3-4	RED TAN	407255 407255	41.5" 41.5"	CHAN 50 CHAN 50 RTN
105 106	J110-5 J110-6	J3-5 J3-6	ORN TAN	407255 407255	41.5" 41.5"	CHAN 51 CHAN 51 RTN
107 108	J110-7 J110-8	J3-7 J3-8	YEL TAN	407255 407255	41.5" 41.5"	CHAN 52 CHAN 52 RTN
109 110	J110-9 J110-10	J3-9 J3-10	GRN TAN	407255 407255	41.5" 41.5"	CHAN 53 CHAN 53 RTN
111 112	J111-10 J111-9	J3-11 J3-12	BLU TAN	407255 407255	41.5" 41.5"	CHAN 54 CHAN 54 RTN
113 114	J111-8 J111-7	J3-13 J3-14	VIO TAN	407255 407255	41.5" 41.5"	CHAN 55 CHAN 55 RTN
115 116	J111-6 J111-5	J3-15 J3-16	GRY TAN	407255 407255	41.5" 41.5"	CHAN 56 CHAN 56 RTN
117 118	J111-4 J111-3	J3-17 J3-18	WHT TAN	407255 407255	41.5" 41.5"	CHAN 57 CHAN 57 RTN
119 120	J111-2 J111-1	J3-19 J3-20	BLK TAN	407255 407255	41.5" 41.5"	CHAN 58 CHAN 58 RTN
121 122	J112-1 J112-2	J3-21 J3-22	BRN TAN	407255 407255	41.5" 41.5"	CHAN 59 CHAN 59 RTN
123 124	J112-3 J112-4	J3-23 J3-24	RED TAN	407255 407255	41.5" 41.5"	CHAN 60 CHAN 60 RTN
125 126	J112-5 J112-6	J3-25 J3-26	ORN TAN	407255 407255	41.5" 41.5"	CHAN 61 CHAN 61 RTN
127 128	J112-7 J112-8	J3-27 J3-28	YEL TAN	407255 407255	41.5" 41.5"	CHAN 62 CHAN 62 RTN
129 130	J112-9 J112-10	J3-29 J3-30	GRN TAN	407255 407255	41.5" 41.5"	CHAN 63 CHAN 63 RTN
131 132	J113-10 J113-9	J3-31 J3-32	BLU TAN	407255 407255	41.5" 41.5"	CHAN 64 CHAN 64 RTN
133 134	J113-8 J113-7	J3-33 J3-34	VIO TAN	407255 407255	41.5" 41.5"	CHAN 65 CHAN 65 RTN
135 136	J113-6 J113-5	J3-35 J3-36	GRY TAN	407255 407255	41.5" 41.5"	CHAN 66 CHAN 66 RTN
137 138	J113-4 J113-3	J3-37 J3-38	WHT TAN	407255 407255	41.5" 41.5"	CHAN 67 CHAN 67 RTN
139 140	J113-2 J113-1	J3-39 J3-40	BLK TAN	407255 407255	41.5" 41.5"	CHAN 68 CHAN 68 RTN
141 142	J114-1 J114-2	J3-41 J3-42	BRN TAN	407255 407255	41.5" 41.5"	CHAN 69 CHAN 69 RTN
143 144	J114-3 J114-4	J3-43 J3-44	RED TAN	407255 407255	41.5" 41.5"	CHAN 70 CHAN 70 RTN
145 146	J114-5 J114-6	J3-45 J3-46	ORN TAN	407255 407255	41.5" 41.5"	CHAN 71 CHAN 71 RTN

RACAL Instruments, Inc., 4 Goodyear St., Irvine, CA 92718

DOCUMENT TITLE	SIZE	CODE NO	DOCUMENT NO.	REV
HARNESS ASSY, 1260-14,TTI	A	21793	407273	A
	DRN			SHEET 6 of 8

## ENGINEERING WIRE LIST

WIRE	FROM	TO	TYPE	PART #	WIRE LEN	REFERENCE
147	J114-7	J3-47	YEL	407255	41.5"	CHAN 72
148	J114-8	J3-48	TAN	407255	41.5"	CHAN 72 RTN
149	J114-9	J3-49	GRN	407255	41.5"	EDRVR 00
150	J114-10	J3-50	TAN	407255	41.5"	EDRVR 00 RTN
151	J115-10	J3-51	BLU	407255	41.5"	EDRVR 01
152	J115-9	J3-52	TAN	407255	41.5"	EDRVR 01 RTN
153	J115-8	J3-53	VIO	407255	41.5"	EDRVR 02
154	J115-7	J3-54	TAN	407255	41.5"	EDRVR 02 RTN
155	J115-6	J3-55	GRY	407255	41.5"	EDRVR 03
156	J115-5	J3-56	TAN	407255	41.5"	EDRVR 03 RTN
157	J115-4	J3-57	WHT	407255	41.5"	EDRVR 04
158	J115-3	J3-58	TAN	407255	41.5"	EDRVR 04 RTN
159	J115-2	J3-59	BLK	407255	41.5"	EDRVR 05
160	J115-1	J3-60	TAN	407255	41.5"	EDRVR 05 RTN
161	J116-1	J4-1	BRN	407255	41.5"	CHAN 73
162	J116-2	J4-2	TAN	407255	41.5"	CHAN 73 RTN
163	J116-3	J4-3	RED	407255	41.5"	CHAN 74
164	J116-4	J4-4	TAN	407255	41.5"	CHAN 74 RTN
165	J116-5	J4-5	ORN	407255	41.5"	CHAN 75
166	J116-6	J4-6	TAN	407255	41.5"	CHAN 75 RTN
167	J116-7	J4-7	YEL	407255	41.5"	CHAN 76
168	J116-8	J4-8	TAN	407255	41.5"	CHAN 76 RTN
169	J116-9	J4-9	GRN	407255	41.5"	CHAN 77
170	J116-10	J4-10	TAN	407255	41.5"	CHAN 77 RTN
171	J117-10	J4-11	BLU	407255	41.5"	CHAN 78
172	J117-9	J4-12	TAN	407255	41.5"	CHAN 78 RTN
173	J117-8	J4-13	VIO	407255	41.5"	CHAN 79
174	J117-7	J4-14	TAN	407255	41.5"	CHAN 79 RTN
175	J117-6	J4-15	GRY	407255	41.5"	CHAN 80
176	J117-5	J4-16	TAN	407255	41.5"	CHAN 80 RTN
177	J117-4	J4-17	WHT	407255	41.5"	CHAN 81
178	J117-3	J4-18	TAN	407255	41.5"	CHAN 81 RTN
179	J117-2	J4-19	BLK	407255	41.5"	CHAN 82
180	J117-1	J4-20	TAN	407255	41.5"	CHAN 82 RTN
181	J118-1	J4-21	BRN	407255	41.5"	CIAN 83
182	J118-2	J4-22	TAN	407255	41.5"	CHAN 83 RTN
183	J118-3	J4-23	RED	407255	41.5"	CHAN 84
184	J118-4	J4-24	TAN	407255	41.5"	CHAN 84 RTN
185	J118-5	J4-25	ORN	407255	41.5"	CHAN 85
186	J118-6	J4-26	TAN	407255	41.5"	CHAN 85 RTN
187	J118-7	J4-27	YEL	407255	41.5"	CHAN 86
188	J118-8	J4-28	TAN	407255	41.5"	CHAN 86 RTN
189	J118-9	J4-29	GRN	407255	41.5"	CHAN 87
190	J118-10	J4-30	TAN	407255	41.5"	CHAN 87 RTN
191	J119-10	J4-31	BLU	407255	41.5"	CHAN 88
192	J119-9	J4-32	TAN	407255	41.5"	CHAN 88 RTN
193	J119-8	J4-33	VIO	407255	41.5"	CHAN 89
194	J119-7	J4-34	TAN	407255	41.5"	CHAN 89 RTN

RACAL Instruments, Inc., 4 Goodyear St., Irvine, CA 92718

DOCUMENT TITLE	SIZE	CODE NO	DOCUMENT NO.	REV
HARNESS ASSY, 1260-14,TTI	A	21793	407273	A
	DRN			SHEET 7 of 8



**ENGINEERING WIRE LIST**

WIRE	FROM	TO	TYPE	PART #	WIRE LEN	REFERENCE
195	J119-6	J4-35	GRY	407255	41.5"	CHAN 90
196	J119-5	J4-36	TAN	407255	41.5"	CHAN 90 RTN
197	J119-4	J4-37	WHT	407255	41.5"	CHAN 91
198	J119-3	J4-38	TAN	407255	41.5"	CHAN 91 RTN
199	J119-2	J4-39	BLK	407255	41.5"	CHAN 92
200	J119-1	J4-40	TAN	407255	41.5"	CHAN 92 RTN
201	J120-1	J4-41	BRN	407255	41.5"	CHAN 93
202	J120-2	J4-42	TAN	407255	41.5"	CHAN 93 RTN
203	J120-3	J4-43	RED	407255	41.5"	CHAN 94
204	J120-4	J4-44	TAN	407255	41.5"	CHAN 94 RTN
205	J120-5	J4-45	ORN	407255	41.5"	CHAN 95
206	J120-6	J4-46	TAN	407255	41.5"	CHAN 95 RTN
207	J120-7	J4-47	YEL	407255	41.5"	CHAN 96
208	J120-8	J4-48	TAN	407255	41.5"	CHAN 96 RTN
209	J120-9	J4-49	GRN	407255	41.5"	EDRYR 06
210	J120-10	J4-50	TAN	407255	41.5"	EDRVR 06 RTN
211	J121-10	J4-51	BLU	407255	41.5"	EDRVR 07
212	J121-9	J4-52	TAN	407255	41.5"	EDRVR 07 RTN
213	J121-8	J4-53	VIO	407255	41.5"	EDRVR 08
214	J121-7	J4-54	TAN	407255	41.5"	EDRVR 08 RTN
215	J121-6	J4-55	GRY	407255	41.5"	EDRVR 09
216	J121-5	J4-56	TAN	407255	41.5"	EDRVR 09 RTN
217	J121-4	J4-57	WHT	407255	41.5"	EDRYR 10
218	J121-3	J4-58	TAN	407255	41.5"	EDRVR 10 RTN
219	J121-2	J4-59	BLK	407255	41.5"	EDRVR 11
220	J121-1	J4-60	TAN	407255	41.5"	EDRVR 11 RTN

RACAL Instruments, Inc., 4 Goodyear St., Irvine, CA 92718				
DOCUMENT TITLE	SIZE	CODE NO	DOCUMENT NO.	REV
HARNESS ASSY, 1260-14,TTI	A	21793	407273	A
DRN			SHEET 8 of 8	

This page was left intentionally blank.

## Chapter 7

# PRODUCT SUPPORT

---

### **Product Support**

Racal Instruments has a complete Service and Parts Department. If you need technical assistance or should it be necessary to return your product for repair or calibration, call 1-800-722-3262. If parts are required to repair the product at your facility, call 1-949-859-8999 and ask for the Parts Department.

When sending your instrument in for repair, complete the form in the back of this manual.

For worldwide support and the office closest to your facility, refer to the Support Offices section on the following page.

### **Reshipment Instructions**

Use the original packing material when returning the 1260-14C to Racal Instruments for calibration or servicing. The original shipping crate and associated packaging material will provide the necessary protection for safe reshipment.

If the original packing material is unavailable, contact Racal Instruments Customer Service for information.

## Support Offices

### **Racal Instruments, Inc.**

4 Goodyear St., Irvine, CA 92618-2002  
Tel: (800) 722-3262, FAX: (949) 859-7309

### **Racal Instruments, Ltd.**

480 Bath Road, Slough, Berkshire, SL1 6BE, United Kingdom  
Tel: +44 (0) 8706 080134; FAX: +44 (0) 1753 791290

### **Racal Systems Electronique S.A.**

18 Avenue Dutartre, 78150 LeChesnay, France  
Tel: +33 (1) 3923 2222; FAX: +33 (1) 3923 2225

### **Racal Systems Elettronica s.r.l.**

Strada 2-Palazzo C4, 20090 Milanofiori Assago, Milan, Italy  
Tel: +39 (02) 5750 1796; FAX +39 (02) 5750 1828

### **Racal Elektronik System GmbH.**

Frankenforster Strasse 21, 51427 Bergisch Gladbach, Germany  
Tel: +49 2204 92220; FAX: +49 2204 21491

### **Racal Australia Pty. Ltd.**

3 Powells Road, Brookvale, NSW 2100, Australia  
Tel: +61 (2) 9936 7000, FAX: +61 (2) 9936 7036

### **Racal Electronics Pte. Ltd.**

26 Ayer Rajah Crescent, 04-06/07 Ayer Rajah Industrial Estate,  
Singapore 0513.  
Tel: +65 7792200, FAX: +65 7785400

### **Racal Instruments, Ltd.**

Unit 5, 25F., Mega Trade Center, No 1, Mei Wan Road, Tsuen  
Wan, Hong Kong, PRC  
Tel: +852 2405 5500, FAX: +852 2416 4335